



**MORIN BUILDING  
8570 EXECUTIVE PARK AVENUE  
FAIRFAX, VIRGINIA 22031**

## **INVITATION FOR BIDS**

**Number:** IFB #19-59

**Title:** Furnish and Deliver Meter Boxes, Valve Boxes, and Lids

**Date Issued:** Monday, May 13, 2019

**Deadline for Questions:** 2:00 p.m., Monday, May 27, 2019

**Bid Due Date:** 2:00 p.m., Monday, June 10, 2019

**IFB Delivery Location and Place of Bid Opening:** Procurement Department  
Fairfax Water  
8570 Executive Park Avenue  
Fairfax, Virginia 22031

**Procurement Contact:** Brian Carter  
Buyer I  
Telephone: (703) 289-6264  
Facsimile: (703) 289-6262  
E-Mail: [bcarter@fairfaxwater.org](mailto:bcarter@fairfaxwater.org)

**IFB 19-59**  
**Furnish and Deliver Meter Boxes, Valve Boxes, and Lids**

<b>1.</b>	<b>SUMMARY INFORMATION AND SUBMISSION OF BIDS</b> .....	<b>1</b>
<b>1.1</b>	<b>Introduction</b> .....	<b>1</b>
<b>1.2</b>	<b>Objective</b> .....	<b>1</b>
<b>1.3</b>	<b>Questions and Communications</b> .....	<b>1</b>
<b>1.4</b>	<b>Bid Opening and Instructions for Submitting Bids</b> .....	<b>1</b>
<b>1.5</b>	<b>Bid Submission Form</b> .....	<b>2</b>
<b>1.6</b>	<b>Proprietary Information</b> .....	<b>2</b>
<b>1.7</b>	<b>Addenda to the IFB</b> .....	<b>2</b>
<b>1.8</b>	<b>Receipt of Addenda</b> .....	<b>3</b>
<b>1.9</b>	<b>Late Bids</b> .....	<b>3</b>
<b>1.10</b>	<b>Contract Award</b> .....	<b>3</b>
<b>1.11</b>	<b>Public Notice of Award</b> .....	<b>3</b>
<b>1.12</b>	<b>Definitions</b> .....	<b>3</b>
<b>1.13</b>	<b>Term of Contract and Contract Renewal</b> .....	<b>4</b>
<b>2.</b>	<b>BID SPECIFICATIONS AND RELATED REQUIREMENTS</b> .....	<b>5</b>
<b>2.1</b>	<b>References</b> .....	<b>5</b>
<b>2.2</b>	<b>Meter Box Standards</b> .....	<b>5</b>
<b>2.3</b>	<b>Meter Box Products</b> .....	<b>5</b>
<b>2.4</b>	<b>Meter Box Lid Standards</b> .....	<b>5</b>
<b>2.5</b>	<b>Meter Box Lid Products</b> .....	<b>6</b>
<b>2.6</b>	<b>Valve Box Standards</b> .....	<b>6</b>
<b>2.7</b>	<b>Valve Box Products</b> .....	<b>6</b>
<b>2.8</b>	<b>Access to Manufacturing Plant</b> .....	<b>7</b>
<b>2.9</b>	<b>Approved Products</b> .....	<b>7</b>
<b>2.10</b>	<b>Condition of Materials on Delivery</b> .....	<b>7</b>
<b>2.11</b>	<b>Delivery Locations</b> .....	<b>7</b>
<b>2.12</b>	<b>Estimated Quantities</b> .....	<b>8</b>
<b>2.13</b>	<b>Packing List</b> .....	<b>8</b>
<b>2.14</b>	<b>Priority Customer</b> .....	<b>8</b>
<b>2.15</b>	<b>Insurance Claims against Bidder</b> .....	<b>8</b>
<b>2.16</b>	<b>Warranty</b> .....	<b>8</b>
<b>2.17</b>	<b>References</b> .....	<b>9</b>
<b>3</b>	<b>STANDARD TERMS AND CONDITIONS</b> .....	<b>10</b>
<b>3.1</b>	<b>Term of Contract and Contract Renewal</b> .....	<b>10</b>
<b>3.2</b>	<b>Authorization to do Business in Virginia</b> .....	<b>10</b>
<b>3.3</b>	<b>Additional Quantities</b> .....	<b>10</b>
<b>3.4</b>	<b>Annual Economic Price Adjustment</b> .....	<b>10</b>
<b>3.5</b>	<b>Anti-Discrimination</b> .....	<b>11</b>
<b>3.6</b>	<b>Antitrust</b> .....	<b>11</b>
<b>3.7</b>	<b>Arrearage</b> .....	<b>11</b>
<b>3.8</b>	<b>Assignment of Interest</b> .....	<b>12</b>
<b>3.9</b>	<b>Availability of Funds</b> .....	<b>12</b>
<b>3.10</b>	<b>Cancellation</b> .....	<b>12</b>
<b>3.11</b>	<b>Compliance with Laws, Regulations and Codes</b> .....	<b>12</b>
<b>3.12</b>	<b>Contract Changes / Change Orders</b> .....	<b>12</b>
<b>3.13</b>	<b>Contractor's Responsibilities</b> .....	<b>13</b>
<b>3.14</b>	<b>Debarment Status</b> .....	<b>13</b>

**IFB 19-59**  
**Furnish and Deliver Meter Boxes, Valve Boxes, and Lids**

<b>3.15</b>	<b>Delivery .....</b>	<b>13</b>
<b>3.16</b>	<b>Duration of Bids .....</b>	<b>14</b>
<b>3.17</b>	<b>Ethics in Public Contracting .....</b>	<b>14</b>
<b>3.18</b>	<b>Examination of Records.....</b>	<b>14</b>
<b>3.19</b>	<b>Familiarity with Specifications .....</b>	<b>15</b>
<b>3.20</b>	<b>Force Majeure .....</b>	<b>15</b>
<b>3.21</b>	<b>Formation of Contract.....</b>	<b>15</b>
<b>3.22</b>	<b>Governing Law; Venue; Waiver of Jury Trial.....</b>	<b>16</b>
<b>3.23</b>	<b>Incorporation by Reference.....</b>	<b>16</b>
<b>3.24</b>	<b>Indemnification and Responsibility for Claims and Liability.....</b>	<b>16</b>
<b>3.25</b>	<b>Insurance.....</b>	<b>16</b>
<b>3.26</b>	<b>Negotiation with Low Bidder .....</b>	<b>18</b>
<b>3.27</b>	<b>No Waiver or Estoppel.....</b>	<b>18</b>
<b>3.28</b>	<b>Pass-through Price Increases and Decreases .....</b>	<b>19</b>
<b>3.29</b>	<b>Payment Clauses Required in All Contracts .....</b>	<b>19</b>
<b>3.30</b>	<b>Payment.....</b>	<b>20</b>
<b>3.31</b>	<b>Precedence of Terms .....</b>	<b>21</b>
<b>3.32</b>	<b>Price Firm Period .....</b>	<b>21</b>
<b>3.33</b>	<b>Price and Title.....</b>	<b>21</b>
<b>3.34</b>	<b>Purchase and Sale Transaction.....</b>	<b>21</b>
<b>3.35</b>	<b>Rider Clause.....</b>	<b>21</b>
<b>3.36</b>	<b>Taxes.....</b>	<b>21</b>
<b>3.37</b>	<b>Termination of Contract.....</b>	<b>21</b>
<b>3.38</b>	<b>Unit Prices Prevail.....</b>	<b>22</b>
<b>3.39</b>	<b>Virginia Freedom of Information Act .....</b>	<b>22</b>

**Attachment 1**

**Attachment 2**

**Attachment 3**

**Bid Submission Form**

**References**

**Excerpts from Fairfax Water Approved Products List and  
Standard Details**

**IFB 19-59**  
**Furnish and Deliver Meter Boxes, Valve Boxes, and Lids**

**SECTION 1**

**1. SUMMARY INFORMATION AND SUBMISSION OF BIDS**

**1.1 Introduction**

The Fairfax County Water Authority, doing business as Fairfax Water (FW) was created under the Virginia Water and Waste Authorities Act pursuant to resolutions adopted by Fairfax County on September 26, 1957. Fairfax Water is managed by a ten member Board of Directors appointed for three-year terms by the Fairfax County Board of Supervisors.

**1.2 Objective**

The objective of this Invitation to Bid and resulting contract is to establish a one-year, annually renewable contract(s) with a bidder(s) to provide Fairfax Water with meter boxes, valve boxes and lids as described and defined herein. These materials will be ordered on an as needed basis. There shall be no minimum order quantity. The bid form is separated into two lots. Bidders may bid on either or both lots but if bidding on a specific lot, bidders shall provide a bid for all items within that lot.

**1.3 Questions and Communications**

All contact between prospective Bidders and FW with respect to this solicitation will be formally held at scheduled meetings or in writing through the Issuing Office. Questions and comments regarding the meaning or interpretation of any aspect of this solicitation must be submitted in writing to the Procurement Contact identified on the cover page to this solicitation and must be received on or before the deadline for submitting questions. Only written questions will be accepted. Questions and/or comments which are submitted after the deadline set forth on the cover page to this solicitation will not be answered.

FW shall respond to all timely questions and comments that are properly submitted and are deemed to address a matter that is relevant and substantive in nature within a reasonable period of time, in the form of a written Addendum that will be transmitted to all prospective Bidders at the addresses furnished to FW for such purpose. Oral communications between FW and any Bidder regarding the interpretation or meaning of any aspect of this IFB are not authorized and may not be relied upon for any purpose.

**1.4 Bid Opening and Instructions for Submitting Bids**

The deadline for submitting bids and the location for opening bids is shown on the cover sheet. Bids will be opened immediately following the deadline for submitting bids. Bids will be opened in accordance with the provisions of the Virginia Public Procurement Act.

All bids must be submitted in a sealed package(s), no other form of submission will be accepted (i.e., E-mail, Facsimile, etc.). Bid packages must be identified on the outside as follows:

**IFB 19-59**  
**Furnish and Deliver Meter Boxes, Valve Boxes, and Lids**

From: _____	_____
Name of Bidder	Due Date
Street	IFB No.
City, State, Zip Code	IFB Title

S A M P L E

Attn: Brian Carter

**1.5 Bid Submission Form**

Attachment 1 is the bid submission form. It must be completed and signed by an agent who is fully authorized to bind the individual or organization submitting the offer to sell, to the terms, conditions and specifications contained herein as well as any addenda to this solicitation.

**1.6 Proprietary Information**

- A. Except as provided herein or as otherwise set forth in §2.2-4342 of the Virginia Public Procurement Act (Va. Code Ann. §2.2-4300 *et seq.*, the “Act”), all proceedings, records, contracts and other public records relating to procurement transactions shall be open to inspection in accordance with the Virginia Freedom of Information Act (Va. Code Ann. §2.2-3700 *et seq.*, the “Virginia FOIA”).
- B. A Bidder, Offeror or Contractor shall have the right to identify data or other materials submitted in connection with this procurement as trade secrets or proprietary information, which shall not be subject to inspection pursuant to either §2.2-4342 of the Act or the Virginia FOIA, by submitting to Fairfax Water prior to or at the time of submission of its proposal or bid a separate, written notice on its letterhead stationery setting forth the following: (i) a statement indicating that the Bidder, Offeror, or Contractor wishes to invoke the protections of this section; (ii) an identification of the data or other materials for which protection is sought; and (iii) a statement with regard to why protection is necessary.

**1.7 Addenda to the IFB**

- A. FW reserves the right to amend this solicitation at any time prior to the deadline for submitting Bids. If it becomes necessary to revise any part of this IFB, notice of the revision will be given in the form of an Addendum that will be provided to all prospective Bidders who are on record with FW as having received this solicitation. If, in the opinion of FW, the deadline for the submission of bids does not provide sufficient time for consideration of any Addendum, then such deadline may be extended at the discretion of FW.
- B. It shall be the responsibility of each Bidder to contact the Purchasing Contact identified on the cover page to this solicitation prior to submission of a bid hereunder in order to determine whether any Addenda have been issued in connection with this procurement. Notwithstanding any provision to the contrary, the failure of any Bidder to receive any Addenda shall neither constitute grounds for withdrawal of its bid, nor relieve such Bidder from any responsibility for incorporating the provisions of any Addenda in its proposal.

**IFB 19-59**  
**Furnish and Deliver Meter Boxes, Valve Boxes, and Lids**

**1.8 Receipt of Addenda**

Acknowledge receipt of each addendum by signing it and submitting it by the bid deadline. Failure to return a signed addendum may result in a bid being determined non-responsive.

**1.9 Late Bids**

Bids or unsolicited amendments to bids arriving after the bid submission deadline will not be considered.

**1.10 Contract Award**

Contract award will be made to the lowest responsive and responsible bidder on a total cost or per lot basis, whichever is deemed most advantageous to Fairfax Water.

Whenever the lowest responsive and responsible bidder is a resident of a state other than Virginia and such state under its laws allows a resident contractor of that state a percentage preference, a like preference shall be allowed to the lowest responsive and responsible bidder who is a resident of Virginia and is the next lowest bidder. If the lowest bidder is a resident contractor of a state with an absolute preference, the bid preference shall not be considered.

**1.11 Public Notice of Award**

Public notice of award will be posted on the official FW web site (<http://www.fcwa.org/procurement/index.htm>).

**1.12 Definitions**

- A. **Acceptance** – means the point in time when FW Project Manager confirms in writing that the contract has been completed as contracted for and the Contractor is released from any further obligations. All remaining payments due the Contractor shall be approved for payment at this time.
- B. **Award** – means the decision by FW to execute a contract after all necessary approvals have been obtained.
- C. **Bid** – means the response by a Bidder to an Invitation for Bids issued by a procurement agency to obtain goods or services.
- D. **Bidder** – means any person submitting a response to an IFB.
- E. **Contract** – written agreement between the successful bidder and FW.
- F. **Contractor** – means the successful Bidder receiving a contract as a result of this solicitation.
- G. **Default** – means that the Contractor has failed to fulfill its contractual obligations properly and on time.
- H. **FW** – means Fairfax Water. The terms Owner and FW have the same meaning.
- I. **Notice** – The term “Notice” or the requirement to notify means a written communication delivered in person, by facsimile, or by certified or registered mail to the individual or firm, or to an officer of the Contractor for whom it is intended.
- J. **Owner** – Fairfax County Water Authority.

**IFB 19-59**  
**Furnish and Deliver Meter Boxes, Valve Boxes, and Lids**

- K. **Project** – The term “Project” means the same as the phrase “the Work.”
- L. **Project Manager** – means FW employee assigned to this project for purposes of oversight of the project. The Project Manager is responsible for all aspects of the contract (excluding contract modifications) after contract award, including but not limited to approving design changes, and authorizing payment for completed work.
- M. **Specifications** – The term “Specifications” describes the physical or functional characteristics or the nature of a good, service or construction item required. It may include a description of any requirement for inspecting, testing, or preparing a good, services or construction item for delivery.
- N. **Work** – The word “Work” shall include all material, labor equipment and tools, appliances, machinery, transportation, and appurtenances necessary to perform and complete the Contract, and any such additional items not specifically indicated or described which can be reasonably inferred as belonging to the item described or indicated or as required by industry practice, custom or usage to complete the project as proposed by the Bidder and accepted by FW.

**1.13 Term of Contract and Contract Renewal**

- A. **Term:** The initial contract term shall be July 1, 2019 through June 30, 2020 with the option to extend the contract for an additional four one-year periods, for a maximum total of five years.
- B. **Renewal:** Renewal will be at the then current rates, terms and conditions (see section 3.3“Annual Economic Price Adjustment”). Issuance of a written renewal document and/or purchase order for the optional years will constitute notice of renewal. Failure to renew by the expiration date of the then current contract year will not automatically cancel the contract. FW may retroactively renew the contract at any time prior to the last day of the following contract year providing that FW has not formally canceled the contract.

**END SECTION 1**

**IFB 19-59**  
**Furnish and Deliver Meter Boxes, Valve Boxes, and Lids**

**SECTION 2**

**2. BID SPECIFICATIONS AND RELATED REQUIREMENTS**

**2.1 References**

Fairfax Water's Approved Products List (APL) and Fairfax Water's Standard Details, latest revisions. Comply with the provisions identified in the Meter Boxes, Meter Box Covers and Valve Boxes sections of the APL, as applicable. Conform to standards identified in Standard Details drawings number 4 and 27, as applicable.

**2.2 Meter Box Standards**

Product shall adhere to the latest version of:

- A. ANSI/AWWA C800 - Underground Service Line Valves and Fittings (Also Included: Collected Standards for Service Line Materials)

**2.3 Meter Box Products**

- A. Approved Manufacturers and Models:

- 1. Bingham & Taylor
- 2. Hunt Industries/Mueller Company

- B. Design and Performance Requirements

- 1. Shall be made of PVC only. No molded plastic.
- 2. 18-inch inside diameter x 24-inch L.
- 3. 27-inch inside diameter x 30-inch L.
- 4. Non-tapered.
- 5. Cut-outs are not permitted.
- 6. Minimum Wall Thickness of 1/2-inch.

**2.4 Meter Box Lid Standards**

Product shall adhere to the latest version of:

- A. ASTM A48 - Standard Specification for Gray Iron Castings



**IFB 19-59**  
**Furnish and Deliver Meter Boxes, Valve Boxes, and Lids**

**2.5 Meter Box Lid Products**

A. Approved Manufacturers and Models:

1. R.B. Argawalla/Capital Foundry
2. Creswell Trading Company
3. Bingham & Taylor
4. Uma Foundry

B. Design and Performance Requirements:

1. Class 25 minimum.
2. Meter Box Cover shall comply with Fairfax Water standard detail.
3. Foreign castings are allowed, subject to testing and approval.
4. Country of origin must be cast into production.

**2.6 Valve Box Standards**

Product shall adhere to the latest version of:

- A. ASTM A48 - Standard Specification for Gray Iron Castings

**2.7 Valve Box Products**

A. Approved Manufacturers and Models:

1. Bingham & Taylor - Fig. 4908
2. R.B. Argawalla (India)/Capitol Foundry
3. Creswell Trading Company - Model A-1 (India)
4. EJ - Only product numbers 85557126U, 85556036U & 85556518U
5. Sigma Corporation
6. Star Pipe Products - Model VBFAIRFAXW

B. Design and Performance Requirements:

1. Cast Iron material shall be in accordance with ASTM A48, Class 25 minimum.

**IFB 19-59**  
**Furnish and Deliver Meter Boxes, Valve Boxes, and Lids**

2. All boxes shall have an outside ledge under the top ring.
3. Top outside slip pipe shall not have flange at bottom.
4. Valve boxes shall comply with Fairfax Water standard details.
5. The manufacturer identification and country of origin, if other than U.S., shall be cast into all parts.
6. Minimum weights shall be as follows:
  - Cover 12.5 lbs.
  - Upper Section 37.5 lbs.
  - Lower Section 47.0 lbs.

**2.8 Access to Manufacturing Plant**

Fairfax Water reserves the right to inspect and monitor the production of the materials being furnished under this contract. The Supplier shall provide access to all of the Supplier and manufacturer's production, testing, storage, operation, and other areas if, and when, requested by Fairfax Water's representative.

**2.9 Approved Products**

The specifications list manufacturers whose products have been tested and approved for use by Fairfax Water. If any modifications, changes, or alterations have been made by the manufacturer to previously approved products after product approval, the revised product is not considered to be approved for acceptance under this Contract and will require approval prior to acceptance as an approved product.

**2.10 Condition of Materials on Delivery**

All materials shall be protected to insure against damage while in transit. All materials shall be in new and undamaged condition upon delivery. Materials found damaged or otherwise found unsuitable will be rejected. The supplier shall be responsible for replacing all rejected materials, including all shipping cost.

**2.11 Delivery Locations**

Orders placed by FW will normally be for delivery within Fairfax County. FW has three property yards within Fairfax County. One is located in Chantilly, Virginia, 20151, one is located in Lorton, Virginia, 22079, and one is located in Falls Church, Virginia, 22046. FW reserves the right to have orders delivered outside of the County for storage purposes.

**IFB 19-59**  
**Furnish and Deliver Meter Boxes, Valve Boxes, and Lids**

**2.12 Estimated Quantities**

The quantities specified herein are estimates based upon current consumption and projected demand for the next contract year, and shall not be construed to represent an amount which FW shall be obligated to purchase. The exact amounts ordered may be more or less subject to FW's actual needs. Bidder acknowledges and agrees that FW will only be responsible for the amounts actually purchased. The exact amounts ordered may be more or less subject to the actual needs of the Members.

**2.13 Packing List**

A packing list shall accompany every shipment. The absence of a packing slip or required shipping order information may cause refusal of the shipment. The packing list shall contain: Purchase Order number, Delivery release number, item description, quantity shipped, quantity ordered, and quantity backordered (if any).

**2.14 Priority Customer**

By submitting a Bid in response to this solicitation, Bidder understands and acknowledges that FW provides services that are essential to the health and welfare of the public. Failure of a Contractor to provide materials under any Contract issued pursuant to this IFB may jeopardize FW's ability to provide timely services, which may affect the health and welfare of the public served by FW. In the event of product shortages at any level of the production to delivery chain, Bidder agrees and affirms that FW will be given the earliest possible notice and the highest priority for allocation of the item(s) listed herein. To the extent that the successful Bidder must prioritize and/or allocate delivery among its customers, the requirements of FW will be honored before contract items are provided to a customer with no obligations with regard to the public health and welfare.

**2.15 Insurance Claims against Bidder.**

In addition to the mandatory insurance requirements listed in Subsection 3.25 (Insurance Requirements) and at the request of FW, the apparent low bidder shall submit a list of all insurance claims made against it within the past 12 months. Failure to include this information within ten calendar days of request by FW may result in rejection of your bid.

**2.16 Warranty**

- A. In addition to any other warranties expressed or implied, the specific warranties of Merchantability and Fitness for a Particular Purpose apply to all orders placed as a result of this solicitation.
- B. If at any time, any contract item fails to conform to the bid/contract specifications, the Contractor shall, at no additional cost to FW, promptly replace the defective item. If the Contractor is unable to remedy such nonconformity during a time period consistent with the requirements, FW may undertake to remedy the nonconformity and in such case Contractor shall reimburse FW for any costs thereby incurred.

**IFB 19-59**  
**Furnish and Deliver Meter Boxes, Valve Boxes, and Lids**

- C. Provide one-year parts and labor warranty. Warranty is to be effective upon receipt at FW. Warranty is to be with either the manufacturer or a service facility authorized by the manufacturer to perform warranty services. On the bid summary sheet, specify where warranty service will be performed: at FW, Manufacture, or bidder's location. If other than at FW, include the name, address and telephone number of the repair facility. All costs for warranty service (including shipping and insurance) shall be included in the warranty and at no additional cost to FW.

**2.17 References**

Each Bidder must submit with its Bid, three references (See Attachment 2 – References). References shall be from customers of similar size and scope of operations as FW, to whom the Bidder has supplied the same products within the past 12 months. References must be able to attest without reservation to the fact that the Bidder provided the contracted goods without a significant problem of any kind, and at any time during the contract period.

**END SECTION 2**

**IFB 19-59**  
**Furnish and Deliver Meter Boxes, Valve Boxes, and Lids**

**SECTION 3**

**3 STANDARD TERMS AND CONDITIONS**

**3.1 Term of Contract and Contract Renewal**

- A. Term: The initial contract term shall be July 1, 2019 through June 30, 2020 with the option to extend the contract for an additional four one-year periods, for a maximum total of five years.
- B. Renewal: Renewal will be at the then current rates, terms and conditions (see section 3.4“Annual Economic Price Adjustment”). Issuance of a written renewal document and/or purchase order for the optional years will constitute notice of renewal. Failure to renew by the expiration date of the then current contract year will not automatically cancel the contract. FW may retroactively renew the contract at any time prior to the last day of the following contract year providing that FW has not formally canceled the contract.

**3.2 Authorization to do Business in Virginia**

Each bidder that is organized or authorized to transact business in the Commonwealth of Virginia pursuant to Title 13.1 or Title 50 of the Virginia Code shall include with its bid the identification number issued to it by the Virginia State Corporation Commission. Any bidder that is not authorized to transact business in Virginia as a foreign entity under Title 13.1 or title 50 of the Virginia Code or as otherwise required by law shall include in its bid a statement describing why the bidder is not required to be so authorized.

**3.3 Additional Quantities**

FW reserves the right to purchase additional quantities of the goods or services specified herein at the bid price for up to one year from the date of contract award. By submitting a bid in response to this solicitation, bidder agrees to provide the item bid, or the then current version of the bid item at the price originally bid.

**3.4 Annual Economic Price Adjustment**

- A. In the case of annually renewable contracts, the Contractors may submit a request for contract price increases once annually for each renewal year. Economic increases shall be limited to the increase specified in the Bureau of Labor Statistics for the 12 month period ending 90 days prior to the end of the then current contract year.
- B. For services: Annual rate increases will be based on the Consumer Price Index-U (CPI-U).
- C. For commodities: If the CPI-U is not the appropriate index for the item(s) being bid, the bidder may substitute any other single BLS price index (e.g. Producer Price Index – metals) providing that the substitute price index constitutes the greatest component of the contract item. Multiple price indexes will not be considered for the same bid item. Bidder may specify a different index for different bid items based on the conditions identified above. Bidder must specify the specific BLS Group and BLS Item that is to be used.

**IFB 19-59**  
**Furnish and Deliver Meter Boxes, Valve Boxes, and Lids**

D. Negative BLS index: If the agreed upon index is a negative number the contractor shall reduce contract rates by the same amount for new contract year.

**3.5 Anti-Discrimination**

By submitting their bids, Bidders certify to FW that they will conform to the provisions of the Federal Civil Rights Act of 1964, as amended, as well as the Virginia Fair Employment Contracting Act of 1975, as amended, where applicable, the Virginians With Disabilities Act, the Americans With Disabilities Act and §11-51 of the Virginia Public Procurement Act.

A. During the performance of the contract, the Contractor agrees as follows:

1. The Contractor will not discriminate against any employee or applicant for employment because of race, religion, color, sex, national origin, or disabilities, except where religion, sex or national origin is a bona fide occupational qualification reasonably necessary to the normal operation of the Contractor. The Contractor agrees to post in conspicuous places, available to employees and applicants for employment, notices setting forth the provisions of this nondiscrimination clause.
2. The Contractor, in all solicitations or advertisements for employees placed by or on behalf of the Contractor, will state that such Contractor is an equal opportunity employer.
3. Notices, advertisements and solicitations placed in accordance with federal law, rule or regulation shall be deemed sufficient for the purpose of meeting these requirements.

B. The Contractor will include the provisions above in every subcontract or purchase order so that the provisions will be binding upon each subcontractor or vendor.

C. Fairfax Water does not discriminate against faith-based organizations on the basis of the organization's religious character, or impose conditions that (a) restrict the religious character of the faith-based organization, except as provided by law, or (b) impair, diminish, or discourage the exercise of religious freedom by the recipients of such goods, services, or disbursements.

**3.6 Antitrust**

By entering into a contract, the Contractor conveys, sells, assigns, and transfers to FW all rights, title and interest in and to all causes of action it may now have or hereafter acquire under the antitrust laws of the United States and the Commonwealth of Virginia, relating to the particular goods or services purchased or acquired by FW.

**3.7 Arrearage**

By submitting a Bid in response to this solicitation, the individual or firm submitting the bid shall be deemed to represent that it is not in arrears in the payment of any obligation due and owing FW, the Commonwealth of Virginia, or any public body in the Commonwealth of Virginia, including but not limited to any obligation to pay taxes and/or employee benefits. Bidder further agrees that it shall make diligent efforts to avoid becoming in arrears during the Term of any Contract awarded hereunder.

**IFB 19-59**  
**Furnish and Deliver Meter Boxes, Valve Boxes, and Lids**

**3.8 Assignment of Interest**

The Contractor shall not assign any interest in any resulting Contract and shall not transfer any interest in the same without prior written consent of FW, which FW shall be under no obligation to grant.

**3.9 Availability of Funds**

It is understood and agreed between the parties herein that FW shall be bound hereunder only to the extent of the funds available or which may hereafter become available for the purpose of this agreement.

**3.10 Cancellation**

FW may cancel this solicitation at any time and for any reason prior to contract award.

**3.11 Compliance with Laws, Regulations and Codes**

The Bidder hereby represents and warrants that:

- A. It is qualified and properly licensed to do business in the Commonwealth of Virginia and that it will take such action as, from time to time hereafter, may be necessary to remain so qualified;
- B. It is not in arrears with respect to the payment of any monies due and owing FW, the Commonwealth of Virginia, or any department or unit thereof, including but not limited to the payment of taxes and employee benefits, and that it shall not become so in arrears during the term of this Contract;
- C. It shall comply with all federal, State and local laws, regulations, and ordinances applicable to its activities and obligations under this Contract; and
- D. It shall obtain at its expense, all licenses, permits, insurance, and governmental approval, if any, necessary to the performance of its obligations under this Contract.

**3.12 Contract Changes / Change Orders**

- A. No verbal agreement or conversation with any officer, agent or employee of FW either before or after the execution of any Contract resulting from this solicitation or follow-on negotiations, shall affect or modify any of the terms, conditions, specifications, or obligations contained in the solicitation, or resulting Contract. No alterations to the terms and conditions of the Contract shall be valid or binding upon FW unless made in writing and signed by the purchasing contact identified on the cover page. Contract changes shall be in writing, and shall be on official FW Purchasing Department letterhead. In any event and in all circumstances, the Contractor shall be solely liable and responsible for any Contract changes, deviations, etc., made without first receiving written authorization to deviate from the Contract by the FW Project Manager.
- B. Changes can be made to the contract in any of the following ways:
  - 1. The parties may agree in writing to modify the scope of the contract. An increase or decrease in the price of the contract resulting from such modification shall be agreed to by the parties as a part of their written agreement to modify the scope of the contract.
  - 2. FW may order changes within the general scope of the contract at any time by Notice to the Contractor. Changes within the scope of the contract include, but are not limited to, things such as services to be performed, the method of packing or shipment, and the place of delivery or installation. The Contractor shall comply with the notice upon receipt. The Contractor shall be

**IFB 19-59**  
**Furnish and Deliver Meter Boxes, Valve Boxes, and Lids**

compensated for any additional costs incurred as the result of such order and shall give FW a credit for any savings. Said compensation shall be determined by one of the following methods:

- a. By mutual agreement between the parties in writing; or
- b. By agreeing upon a unit price or using a unit price set forth in the contract, if the work to be done can be expressed in units, and the Contractor accounts for the number of units of work performed, subject to FW's right to audit the Contractor's records and/or to determine the correct number of units independently; or
- c. By ordering the Contractor to proceed with the work and keep a record of all costs incurred and savings realized. A markup for overhead and profit may be allowed if provided by the contract. The same markup shall be used for determining a decrease in price as the result of savings realized. The Contractor shall present FW with all vouchers and records of expenses incurred and savings realized. FW shall have the right to audit the records of the Contractor, as it deems necessary to determine costs or savings. Any claim for an adjustment in price under this provision must be asserted by Notice to the Purchasing Department. Neither the existence of a claim nor a dispute resolution process, litigation or any other provision of this contract shall excuse the Contractor from promptly complying with the changes ordered by FW or with the performance of the contract generally.

**3.13 Contractor's Responsibilities**

- A. The Contractor shall be responsible for all products and/or services as required by this IFB. The use of subcontractors is prohibited unless:
  1. A request to include a subcontractor is included in the bid and,
  2. The Bidder receives written approval to use a subcontractor prior to, or as part of the formal contract between the parties.
- B. Even when properly authorized by FW, the use of a subcontractor does not relieve the Contractor of liability under the contract.
- C. The Contractor, at its sole expense, shall be responsible for damage to FW and non-FW property as a result of its failure, or its subcontractor's failure to protect such facilities and utilities.
- D. The Contractor, at its sole expense, shall immediately repair or replace FW property damaged by (or caused by) the Contractor or its Subcontractor(s). Replacements will be of equal or better quality than the property damaged property, and all such work must be approved by FW Project Manager.

**3.14 Debarment Status**

By submitting a Bid in response to this solicitation, each Bidder certifies that it is not currently debarred by the federal government, the Commonwealth of Virginia, or any agency or department thereof from submitting a bid or proposal in connection with any procurement project and that it is not an agent of any person or entity that currently is so debarred.

**3.15 Delivery**

In the case of solicitations that require delivery to FW:



**IFB 19-59**  
**Furnish and Deliver Meter Boxes, Valve Boxes, and Lids**

- A. By submitting a bid in response to this solicitation, the Bidder guarantees delivery of contract items within the timeframe specified herein or as indicated in the bidders bid submission form. Failure to deliver within the time specified, or as amended in writing by FW, or failure to make replacements of rejected Contract items, shall constitute a breach of contract and may be grounds for a declaration of default in addition to any other remedies FW may be entitled to.
- B. Deliveries must be made by within the delivery time specified in the bid submission document. If a delay is anticipated, the Contractor must provide as much advanced notice as possible to FW. Failure to honor a delivery schedule may result in damages to FW. The Contractor is liable for any and all costs incurred by FW due to such failures.
- C. Homeland Security Advisory System: If the Homeland Security Advisor System places the water / waste water industry in Codes Orange or Red, all deliveries shall be between the hours 7:30 a.m. and 2:00 p.m., Monday through Friday unless specially requested by the plant. As each delivery leaves the Contractor's yard, the Plant is to be advised as to the driver's name and trailer number and estimated arrival time. Upon arrival, the driver will be required to show photo ID and the trailer number will be checked and verified before delivery is allowed on site. Failure to follow these procedures may result in a refusal of the delivery at the Contractor's risk and expense.

**3.16 Duration of Bids**

Bids shall be valid for a minimum of 90 days following the deadline for submitting bids. If an award is not made during that period, all bids shall be automatically extended for another 90 days. Bids will be automatically renewed until such time as either an award is made or proper notice is given to FW of Bidder's intent to withdraw its bid. Bids may only be withdrawn by submitting written notice at least seven days before the expiration of the then current 90-day period.

**3.17 Ethics in Public Contracting**

Contractor hereby certifies that it has familiarized itself with Article 4 of Title 11 of the Virginia Public Procurement Act, Section 11-72 through 80, Virginia Code Annotated, and that all amounts received by it, pursuant to a contract resulting from this solicitation, are proper and in accordance therewith.

**3.18 Examination of Records**

Bidder agrees that in any resulting contract, either FW or its duly authorized representative shall have access to and the right to examine and copy any directly pertinent books, documents, papers, and records of the Contractor involving transactions related to any resulting contract. This obligation shall expire five years after the final payment for the final service performed as a result of any and all contract(s) awarded pursuant to this solicitation, or until audited by FW, whichever is sooner. Contractor will provide reasonable access to any and all necessary documents and upon demand provide copies of documents if so required by FW or its representative(s). FW will reimburse the Contractor for any reasonable expenses it incurs as a result of such a request.

**IFB 19-59**  
**Furnish and Deliver Meter Boxes, Valve Boxes, and Lids**

**3.19 Familiarity with Specifications**

Each Bidder shall bear responsibility for thoroughly examining this solicitation in its entirety. In the event that Bidder has any questions or comments regarding the proper meaning or intent of any aspect of this solicitation, then such Bidder shall submit all such questions and comments in writing to the Procurement Contact identified on the cover sheet of this solicitation.

The submission by a Bidder of a Bid in response to this solicitation shall be deemed to constitute a representation on the part of such Bidder that it has thoroughly examined this solicitation and has submitted any and all questions and comments it may have regarding the meaning or interpretation of this solicitation to Fairfax Water in the manner prescribed herein.

**3.20 Force Majeure**

If a delivery is delayed by Act of God, terrorism, war, embargo, fire, or explosion not caused by the negligence or intentional act of the Contractor or his subcontractors or supplier(s), a reasonable extension of time as FW deems appropriate may be granted. Upon receipt of a written request and justification for any extension from the Contractor FW may in its sole discretion (i) extend the time for delivery of the Commodity; (ii) suspend the Contract in whole or in part and obtain one or more of the Commodities elsewhere for a time, or (iii) terminate the Contract; all without liability to Contractor on the part of FW, as the case may be. Contractor's request and justification shall be subject to such substantiation and further inquiries as FW may require.

**3.21 Formation of Contract**

- A. The words "Contract" and "Purchase Order" are used interchangeably unless the context otherwise plainly requires. The documents comprising the Contract shall be accorded the following order of precedence:
  - 1. Any Change Orders;
  - 2. All Purchase Orders;
  - 3. Any Addenda to the IFB;
  - 4. This IFB (including all Appendices and Attachments hereto); and
  - 5. The Bidder's completed Bid Tabulation Form (including any drawings and submittals).
  
- B. The contract to be entered into as a result of this IFB shall be by and between the Bidder as Contractor and FW. It shall include the following items, which are listed in order of precedence:
  - 1. The fully executed contract between the parties, or FW Purchase Order,
  - 2. The IFB and any Addenda to the IFB,
  - 3. The Bidder's response to the IFB (including any drawings and submittals), and
  - 4. All correspondence between the parties regarding this IFB.
  
- C. Anything called for by one of the contract documents and not called for by the others shall be of like effect as if required or called for by all, except that a provision clearly designed to negate or alter a provision contained in one or more of the other contract documents shall have the intended effect.

**IFB 19-59**  
**Furnish and Deliver Meter Boxes, Valve Boxes, and Lids**

**3.22 Governing Law; Venue; Waiver of Jury Trial**

Notwithstanding any provision to the contrary, this solicitation and any resulting contract shall be governed in all respects by the laws of the Commonwealth of Virginia. Any dispute arising hereunder which is not otherwise resolved by the parties shall be resolved by a court of competent jurisdiction in the Commonwealth of Virginia. The Contractor and FW hereby waive any right such party may have to a trial by jury in connection with any such litigation.

**3.23 Incorporation by Reference**

This solicitation is issued in accordance with, and controlled by, the Virginia Public Procurement Act (VPPA), which is incorporated into and made part of the solicitation. By submitting a bid in response to this solicitation, all Bidders acknowledge the VPPA and agree to be bound by it. A copy of the VPPA is available for inspection at the Purchasing Department at FW. It is also available at the Virginia Department of General Services, Department of Purchases and Supply Website:

<http://www.eva.virginia.gov/pages/eva-vppa.htm>

**3.24 Indemnification and Responsibility for Claims and Liability**

With respect to any contract that results from this solicitation, Bidder is bound by the following:

- A. The Contractor shall indemnify, save harmless and defend FW, or any employee of FW, against liability for any suits, actions, or claims of any character whatsoever arising from or relating to the Contractor's negligence or willful misconduct in the performance of the Contractor or its subcontractors under this contract.
- B. FW has no obligation to provide legal counsel or defense, or pay attorney's fees to the Contractor or its subcontractors in the event that a suit or action of any character is brought by any person not party to the contract, against the Contractor or its subcontractors as a result of or relating to the Contractor's obligations under this contract.
- C. FW has no obligation for the payment of any judgments or the settlement of any claims against the Contractor or its subcontractors as a result of or relating to the Contractor's obligations under this contract.
- D. The Contractor shall pay all royalties and license fees necessary for performance of the contract. The Contractor shall defend all suits or claims for infringement of any patent rights or other proprietary rights arising from or related to performance of the resulting contract and shall save FW harmless from any loss, including Attorneys' fees arising out of any such claim.

**3.25 Insurance**

- A. In addition to the mandatory insurance requirements listed in this Section and, at the request of FW, any Bidder may be required to provide a list of all insurance claims made against it within the past 36 months. FW reserves the right to reject any bid if in FW's opinion the amount or number of claims

**IFB 19-59**  
**Furnish and Deliver Meter Boxes, Valve Boxes, and Lids**

is deemed to be excessive. An Bidder's failure to comply with this requirement may result in rejection of its bid. If no claims have been made, then the Bidder shall so state in its bid. Fairfax Water may require such information from the Contractor as it deems necessary to assess the Contractor's financial ability to pay any deductibles with respect to the insurance policies required hereunder.

- B. Before commencing the work, the Contractor shall procure and maintain at its own expense, minimum insurance in forms and with insurance companies acceptable to FW to cover loss or liability arising out of the Work. All insurance policies must be underwritten by insurers authorized to conduct business within the Commonwealth of Virginia and must have a Best's rating of at least A- and a financial size of class VIII or better in the latest edition of Best's Insurance Reports.
- C. The Contractor shall immediately notify FW of any claim or suit made or filed against the Contractor or its subcontractors regarding any matter resulting from or related to the Contractor's obligations under the contract. If such a claim or suit is brought, the Contractor will cooperate, assist, and consult with FW in the defense or investigation of any suit or action made or filed against FW as a result of or relating to the Contractor's performance under this contract.
- D. With the exception of Workers' Compensation and Employers' Liability Insurance, all additional insurance policies specified herein shall name FW as an additional insured with regard to work performed under any subsequent Contract
- E. The Contractor will provide FW with copies of certificates of insurance coverage and proof of payment of all premiums. Each certificate of insurance must include: (a) an endorsement from the insurer that certifies that the Contractor maintains the referenced policy in full force and effect; (b) where applicable, a statement indicating that FW is included as an additional insured; and (c) a provision requiring that not less than 30 days written notice will be given to FW before any policy or coverage is canceled or modified in any material respect. Without limiting the requirements set forth above, the insurance coverages will include a minimum of:
  - 1. Workers' Compensation and Employers' Liability Insurance: Statutory requirements and benefits as required by the Commonwealth of Virginia; and
  - 2. Required Commercial General Liability Insurance: This insurance must be written on an "occurrence" basis and shall be endorsed to include FW as an additional insured and shall provide at a minimum the following:

◆ General Aggregate Limit (Other than Products-Completed Operations)	\$1,000,000
◆ Products-Completed Operations Aggregate Limit	\$ 500,000
◆ Personal & Advertising Injury Limit	\$ 500,000
◆ Each Occurrence Limit	\$ 500,000
For Construction Contracts:	
◆ Directors & Officers – Errors & Omissions	\$2,000,000
- F. Business Automobile Liability Insurance: This insurance coverage must extend to any motor vehicles or other motorized equipment regardless of whether it is owned, hired, or non-owned and must cover Bodily Injury and Property Damage with a combined single limit of at least \$500,000 each accident. This insurance must be written in comprehensive form and must protect the Contractor and FW against claims for injuries to members of the public and/or damage to the property of others arising

**IFB 19-59**  
**Furnish and Deliver Meter Boxes, Valve Boxes, and Lids**

from the Contractor's use of motor vehicles or other equipment and must cover both on-site and off-site operations.

- G. Nothing contained herein will be deemed to operate as a waiver of FW's sovereign immunity under the law.

**3.26 Negotiation with Low Bidder**

If the lowest bid submitted by a responsive and responsible bidder exceeds available funds for this procurement, then Fairfax Water may, in its discretion, conduct negotiations with the lowest responsive and responsible bidder (the "Low Bidder") in an effort to obtain a contract price that is within available funds. In such event, Fairfax Water will notify the Low Bidder verbally or in writing that its bid exceeds available funds and will schedule a conference with the Low Bidder, Fairfax Water staff, and such advisors and consultants as Fairfax Water deems appropriate in order to discuss possible modifications to the scope of the procurement that may result in a price that is within available funds. The conference and any subsequent negotiations may be conducted in person or by telephone. If, during the conference, the parties arrive at an acceptable modification to the scope of the project and a contract price that is within available funds, then Fairfax Water may award a contract to the Low Bidder based upon the newly-modified terms and conditions. Otherwise, the Low Bidder will, within 15 days after the date of the conference (or such longer or shorter period as may be specified in writing by Fairfax Water), submit to Fairfax Water a written addendum to its original Bid Form which describes its proposed modification(s) to the scope of the procurement and sets forth the Low Bidder's newly adjusted bid price. Fairfax Water may conduct further negotiations with the Low Bidder or request additional clarifications or modifications. If the Low Bidder's proposed modifications are acceptable to Fairfax Water and the associated contract price is within available funds, then Fairfax Water may award a contract to the Low Bidder based upon the modified terms and conditions. If the proposed modifications are not acceptable to Fairfax Water, or the associated price reductions are not within available funds, then Fairfax Water will terminate negotiations and reject all bids.

**3.27 No Waiver or Estoppel**

Neither the inspection by FW nor any of its employees, nor any payment of money, nor payment for, nor acceptance of any Commodity by FW, nor any extension of time shall operate as a waiver of any provision of this Contract, or of any power herein reserved to the Owner or of any right to damage herein provided. No waiver of any breach of this Contract shall be held to be a waiver of any other subsequent breach. All remedies provided in this Contract to FW shall be construed as cumulative and shall be in addition to each and every other remedy herein provided. Neither FW, nor any officer, employee, or authorized representative of FW, will be bound, precluded, or estopped by any action, determination, decision, acceptance, return, certificate, or payment made or given under or in connection with the Contract by any officer, employee or authorized representative of the Owner, at any time either before or after final completion and acceptance of the Work and payment therefore from: (a) showing the true and correct classification, amount, quality, or character of the Commodities delivered, or that any determination, decision, acceptance, return certificate or payment was incorrect or was improperly made in any respect, or that the Commodities or any part thereof do not in fact conform to the requirements of the Contract; (b) demanding and recovering from the Contractor any overpayment made to the Contractor or such damages as FW may sustain by reason of the Contractor's failure to comply with the requirements of the Contract; or (c) both of the foregoing clauses (a) and (b).

**IFB 19-59**  
**Furnish and Deliver Meter Boxes, Valve Boxes, and Lids**

**3.28 Pass-through Price Increases and Decreases**

For annually renewable contracts:

- A. Increases: FW recognizes that the Contractor's sources of supply and transportation may pass onto the Contractor unanticipated and significant price increases. FW will consider requests by the Contractor to allow "pass-through" price increases when accompanied with sufficient proof. Only the Contractor's direct supplier's price increases will be considered. FW reserves the right to accept or reject all such requests. FW will not allow price increases that are greater than the amount passed on to the Contractor, or for a period outside of the then current contract year.
- B. Decreases:
  - 1. Pass through price increases shall cease at the end of the then current contract year and contract pricing will return to the pre-pass through rate. The contractor will be eligible for and only upon request, the annual economic price increase as defined in subsection 3.3 above.
  - 2. Prior to the end of the then current contract year, the pass through increase shall be reduced or eliminated when and as the cause of the increase is reduced or eliminated.
- C. Pass through price increases will not be a substitute for poor planning by the Contractor. Pass through increase will not be allowed for the first six months of any contract year. Price increases will be effective upon the date such a request is received in writing; and will not be made retroactive.

**3.29 Payment Clauses Required in All Contracts**

Section § 2.2-4352 of the Virginia Public Procurement Act requires the following:

- A. That any contract awarded by FW include the following clauses:
  - 1. The Contractor shall take one of the two following actions within seven days after receipt of amounts paid to the contractor by FW for work performed by any subcontractor(s) under the contract:
    - a. The Contractor shall pay its subcontractor(s) for the proportionate share of the total payment received from FW attributable to the work performed by the subcontractor under that contract; or
    - b. Notify FW and any subcontractor(s), in writing, of his intention to withhold all or a part of the subcontractor's payment with the reason for nonpayment.
  - 2. Bidders shall include in their offer submissions either: (i) if an individual contractor, their social security numbers; and (ii) proprietorships, partnerships, and corporations to provide their federal employer identification numbers.
  - 3. The contractor shall pay interest to the subcontractor(s) on all amounts owed by the Contractor that remain unpaid after seven days following receipt by the Contractor of payment from FW for work performed by the subcontractor under the contract, except for amounts withheld as allowed in subdivision 1.
  - 4. Unless otherwise provided under the terms of this contract, interest shall accrue at the rate of one percent per month.

**IFB 19-59**  
**Furnish and Deliver Meter Boxes, Valve Boxes, and Lids**

- B. The contractor shall include in each of its subcontracts a provision requiring each subcontractor to include or otherwise be subject to the same payment and interest requirements with respect to each lower-tier subcontractor.
- C. A contractor's obligation to pay an interest charge to a subcontractor pursuant to the payment clause in this section shall not be construed to be an obligation of FW. A contract modification shall not be made for the purpose of providing reimbursement for the interest charge. A cost reimbursement claim shall not include any amount for reimbursement for the interest charge.

**3.30 Payment**

- A. Invoices: All invoices are to be sent directly to FW Accounts Payable department by mail, fax, or e-mail. Invoices shall include the FW Purchase Order / Contract number and the contractor's FEIN. Invoices are not to be sent to the contract Project Manager, or other departmental reps. Failure to comply may result in late payments for which FW will not be liable.
- B. Terms: All payments will be Net 30 from the date of receipt of a valid invoice at FW Finance Department. Payment terms requiring payment in less than 30 days will be regarded as requiring payment 30 days after invoice or delivery, whichever occurs last. This shall not affect offers of discounts for payment in less than 30 days, however.
- C. Invoices: The Contractor shall submit invoices for items ordered, delivered and accepted, directly to the Finance Department, to the attention of Accounts Payable. Invoices shall show FW Purchase Order or contract number and are subject to review and approval by FW Project Manager
- D. Partial Payments: Requests for partial payments or advanced payments must be submitted as part of the Price Bid along with a justification. FW reserves the right to accept, reject or negotiate requests for partial payments. If the request is rejected, the Bidder must waive the requirement in order to remain in consideration.
- E. Refunds: If the Contractor is declared to be in default, FW will be eligible for a full and immediate refund for all payments made to the Contractor. Partial Payments: Requests for partial payments or advanced payments must be submitted as part of the Price Offer along with a justification. FW reserves the right to accept, reject or negotiate requests for partial payments. If the request is rejected, the Bidder must waive the requirement in order to remain in consideration.
- F. Unreasonable Charges: Under certain emergency procurements and for most time and material purchases, final job costs cannot be accurately determined at the time orders are placed. In such cases, final payment is contingent on a determination of reasonableness with respect to all invoiced charges. Charges that appear to be unreasonable will be researched and challenged, and that portion of the invoice held in abeyance until a settlement can be reached. Upon determining that invoiced charges are not reasonable, FW shall promptly notify the Contractor, in writing, as to those charges that it considers unreasonable and the basis for the determination.

**IFB 19-59**  
**Furnish and Deliver Meter Boxes, Valve Boxes, and Lids**

**3.31 Precedence of Terms**

These General Terms and Conditions shall apply in all instances. In the event there is a conflict between any of the other General Terms and Conditions and any Special Terms and Conditions in this solicitation, the Special Terms and Conditions shall apply.

**3.32 Price Firm Period**

Bid pricing shall be firm and fixed as originally offered and accepted for the first 12 months of the contract.

**3.33 Price and Title**

All prices are for Commodities delivered F.O.B. the facility set forth on the Purchase Order and shall represent the entire cost to FW. Title for such Commodities shall pass to FW upon receipt and acceptance thereof at FW's designated facility.

**3.34 Purchase and Sale Transaction**

Any transaction for the purchase and sale of any Commodity shall be effected by FW's issuance to the Contractor of a Purchase Order, in which event the Contractor covenants and agrees to furnish all Commodities described therein in strict accordance with the terms and conditions of such Purchase Order and the other documents that together constitute the Contract.

**3.35 Rider Clause**

Subject to the mutual agreement between the parties, any contract awarded on the basis of this solicitation may be used by any public entity (to include jurisdictions comprising the Metropolitan Washington Council of Governments), to enter into a contract for the services described and defined herein. For single purchases, the contract may be used for up to 12 months from the actual date of contract award. For multi-year contracts, the contract may be used throughout the effective period of the contract. Contracts awarded as a result of this solicitation will be subject to these terms and conditions, and/or such terms and conditions as may be required by the controlling body for the public agency using the contract. Pricing shall be as offered by the successful Offeror and subsequently accepted by FW.

**3.36 Taxes**

FW is exempt from Federal Excise Taxes, Virginia State Sales and Use Taxes, and the District of Columbia Sales Taxes and Transportation Taxes. FW's tax identification number is 54-6025290.

**3.37 Termination of Contract**

- A. For Cause. In the event that the Contractor: (1) fails to deliver any Commodity or Service in accordance with the time period established therefore in the Contract; or (2) fails to furnish any Commodity or Service which conforms in all respects to the requirements of the Contract; then FW, without prejudice to any other rights or remedies it may have at law or in equity (including its right to seek damages from the Contractor), shall have the right to terminate the Contract and any outstanding Purchase Orders by issuing a written notice of termination to the Contractor. Such notice



**IFB 19-59**  
**Furnish and Deliver Meter Boxes, Valve Boxes, and Lids**

of termination shall describe in reasonable detail the grounds for the termination and shall take effect immediately upon receipt by the Contractor.

If, after issuance of a notice of termination under this Section it is determined for any reason that cause for such termination did not exist, then the rights and obligations of the parties shall be the same as if the notice of termination had been delivered under the provisions of subsection B (termination for convenience) hereof; provided, however, that the Contractor in such event shall be deemed to have received seven days prior written notice of such termination. Any compensation due the Contractor pursuant to subsection B shall be offset by the cost to FW of remedying the default by the Contractor. The Contractor shall in no event be entitled to receive any consequential damages or any anticipated profits with respect to Commodities not yet furnished to, and accepted by, FW as of the effective date of any such termination.

- B. For Convenience. FW shall have the right to terminate the Contract and/or any outstanding Purchase Orders issued hereunder at its own convenience for any reason by giving seven business days prior written notice of termination to the Contractor. In such event, the Contractor shall be paid an amount equal to the actual cost of any Commodity delivered to, and accepted by, FW and the actual cost of any equipment, goods or materials ordered by the Contractor hereunder in good faith which could not be canceled, less the salvage value thereof, provided sufficient substantiation is furnished to FW. Any subcontract entered into by the Contractor in connection with the transactions contemplated hereby shall contain a similar termination provision for the benefit of the Contractor and FW. The Contractor shall in no event be entitled to receive anticipated profits on any Commodities not yet furnished to and accepted by FW as of the effective date of any such termination.

**3.38 Unit Prices Prevail**

In the event that there is a mathematical error on the summary sheet, the unit price for each item shall prevail. All costs to provide the goods and/or services specified in this solicitation shall be shown on the attached bid summary sheet. If there are additional costs to provide the goods and/or services specified herein either list them on the attached bid summary sheet or attach an additional sheet to it. Line items left blank will be interpreted as at no cost to FW.

**3.39 Virginia Freedom of Information Act**

Except as provided herein, all proceedings, records, contracts and other public records relating to procurement transactions shall be open to the inspection of any citizen, any interested person, firm, or corporation, in accordance with the Virginia Freedom of Information Act.

**END SECTION 3**

IFB # 19-59

ATTACHMENT 1

BID SUBMISSION FORM

COMPANY NAME: \_\_\_\_\_

ADDRESS: \_\_\_\_\_  
\_\_\_\_\_

CONTACT PERSON: \_\_\_\_\_

TELEPHONE: \_\_\_\_\_ E-MAIL: \_\_\_\_\_

FAX: \_\_\_\_\_ FED ID #: \_\_\_\_\_

Pursuant to Title 13.1 or Title 50 of the Virginia Code provide the identification number issued to your firm by the Virginia State Corporation Commission (VSCC) in the space provided below, If your firm is not required to be authorized to transact business under Title 12.1 or Title 50, or any other law; provide a statement why your firm is not required to be so authorized.

\_\_\_\_\_

Company Name	Identification Number
--------------	-----------------------

If you do not have a VSCC identification number, explain why it is not required in the space below:

\_\_\_\_\_  
\_\_\_\_\_  
\_\_\_\_\_

All bidders must specify the following information:

Manufacturer being bid: \_\_\_\_\_ Model: \_\_\_\_\_

Bid Item	Description	Quantity	Unit of Issue	Unit Price	Total Price
<b>Lot I – Meter Boxes</b>					
1.	18” x 24” Meter Box	2200	EA	\$	\$
2.	27” x 30” Meter Box	150	EA	\$	\$
<b>Lot I – Meter Boxes Total Price:</b>					\$
<b>Lot II – Cast Lids and Boxes</b>					
3.	18” Meter Box Lid	1200	EA	\$	\$
4.	18” Meter Box Lid w/ 2” AMR Hole	1000	EA	\$	\$
5.	Complete Valve Box, Long	1000	EA	\$	\$
6.	Valve Box Lid	1000	EA	\$	\$

**IFB # 19-59**

Bid Item	Description	Quantity	Unit of Issue	Unit Price	Total Price
7.	Valve Box Top Section, Long, 26"	100	EA	\$	\$
8.	Valve Box Top Section, Short, 15"	200	EA	\$	\$
<b>Lot II – Cast Lids and Boxes Total Price:</b>					\$
<b>Lot I and Lot II Combined Total Price:</b>					\$

\*\* The following shall be submitted with your bid. Failure to provide the following items with your bid may be cause for rejection of bid as non-responsive and/or non-responsible. It is the responsibility of the bidder to ensure that it has received all addenda and to include signed copies with their bid.

1. Addenda, if any
2. Proof of Authority to Transact Business in Virginia
3. BLS Group and Item Index to be used for future renewals, if different from specified in Section 3.4

\* All bids are to be quoted as FOB Destination. Include all necessary costs in your bid submission (see above). Failure to include the cost of shipping and handling will be interpreted as included in the unit price for each item. FW will not pay for shipping and handling charges not included in your bid.

• **TERMS:** \_\_\_\_\_ All bids will be interpreted as 2%-30, Net 31, unless otherwise specified herein. FW's minimum payment term is Net 31 days. By submitting an offer to sell in response to this solicitation, all bidders acknowledge and agree to this requirement.

By my signature I certify that I am acting as an agent or in the case of an LLP, the Partner or Managing Partner for the firm identified below and I am fully authorized to bind the firm to the terms, conditions and specifications of this solicitation, as well as any addenda thereto.

Company Name: \_\_\_\_\_

Signature: \_\_\_\_\_ Printed Name: \_\_\_\_\_

Title: \_\_\_\_\_ Date: \_\_\_\_\_

**IFB # 19-59**

**ATTACHMENT 2**

**REFERENCES**

BIDDER'S NAME: \_\_\_\_\_

1. COMPANY NAME: \_\_\_\_\_

ADDRESS: \_\_\_\_\_

\_\_\_\_\_

\_\_\_\_\_

CONTACT PERSON: \_\_\_\_\_

TELEPHONE: (\_\_\_\_\_) - \_\_\_\_\_ - \_\_\_\_\_

FAX: (\_\_\_\_\_) - \_\_\_\_\_ - \_\_\_\_\_

E-MAIL: \_\_\_\_\_

2. COMPANY NAME: \_\_\_\_\_

ADDRESS: \_\_\_\_\_

\_\_\_\_\_

\_\_\_\_\_

CONTACT PERSON: \_\_\_\_\_

TELEPHONE: (\_\_\_\_\_) - \_\_\_\_\_ - \_\_\_\_\_

FAX: (\_\_\_\_\_) - \_\_\_\_\_ - \_\_\_\_\_

E-MAIL: \_\_\_\_\_

3. COMPANY NAME: \_\_\_\_\_

ADDRESS: \_\_\_\_\_

\_\_\_\_\_

\_\_\_\_\_

CONTACT PERSON: \_\_\_\_\_

TELEPHONE: (\_\_\_\_\_) - \_\_\_\_\_ - \_\_\_\_\_

FAX: (\_\_\_\_\_) - \_\_\_\_\_ - \_\_\_\_\_

E-MAIL: \_\_\_\_\_

**IFB # 19-59**

BIDDERS' NAME: \_\_\_\_\_

4. COMPANY NAME: \_\_\_\_\_

ADDRESS: \_\_\_\_\_

\_\_\_\_\_

CONTACT PERSON: \_\_\_\_\_

TELEPHONE: (\_\_\_\_\_) - \_\_\_\_\_ - \_\_\_\_\_

FAX: (\_\_\_\_\_) - \_\_\_\_\_ - \_\_\_\_\_

E-MAIL: \_\_\_\_\_

5. COMPANY NAME: \_\_\_\_\_

ADDRESS: \_\_\_\_\_

\_\_\_\_\_

CONTACT PERSON: \_\_\_\_\_

TELEPHONE: (\_\_\_\_\_) - \_\_\_\_\_ - \_\_\_\_\_

FAX: (\_\_\_\_\_) - \_\_\_\_\_ - \_\_\_\_\_

E-MAIL: \_\_\_\_\_

# IFB 19-59 Attachment 3

Meter Boxes

## Meter Boxes

### PART 1 – GENERAL

Section includes: applicable referenced standards and technical requirements of the product.

#### ***Summary***

#### **References**

Product shall adhere to the latest version of:

- A. ANSI/AWWA C800 - Underground Service Line Valves and Fittings (Also Included: Collected Standards for Service Line Materials)

#### ***System Description***

#### **Design and Performance Requirements**

Section includes: technical requirements of the product, consisting of, but not limited to material type, dimensions, and conditions.

- A. Shall be made of PVC only. No molded plastic.
- B. 18-inch inside diameter x 24-inch L.
- C. 27-inch inside diameter x 30-inch L.
- D. Non-tapered.
- E. Cut-outs are not permitted.
- F. Minimum Wall Thickness of 1/2-inch.

### PART 2 – PRODUCTS

#### ***Manufacturers***

#### **Approved Manufacturer(s):**

- A. Bingham & Taylor
- B. Hunt Industries/Mueller Company

END OF SECTION

# IFB 19-59 Attachment 3

Meter Box Covers

## Meter Box Covers

### PART 1 – GENERAL

Section includes: applicable referenced standards and technical requirements of the product.

#### ***Summary***

#### **References**

Product shall adhere to the latest version of:

- A. ASTM A48 - Standard Specification for Gray Iron Castings

#### ***System Description***

#### **Design and Performance Requirements**

Section includes: technical requirements of the product, consisting of, but not limited to material type, dimensions, and conditions.

- A. Class 25 minimum.
- B. Meter Box Cover shall comply with Fairfax Water standard detail.
- C. Foreign castings are allowed, subject to testing and approval.
- D. Country of origin must be cast into production.

### PART 2 – PRODUCTS

#### ***Manufacturers***

#### **Approved Manufacturer(s):**

- A. R.B. Argawalla/Capital Foundry
- B. Creswell Trading Company
- C. Bingham & Taylor
- D. Uma Foundry

END OF SECTION

# IFB 19-59 Attachment 3

Valve Boxes

## Valve Boxes

### PART 1 – GENERAL

Section includes: applicable referenced standards and technical requirements of the product.

#### **Summary**

#### **References**

Product shall adhere to the latest version of:

- A. ASTM A48 - Standard Specification for Gray Iron Castings

#### **System Description**

#### **Design and Performance Requirements**

Section includes: technical requirements of the product, consisting of, but not limited to material type, dimensions, and conditions.

- A. Cast Iron material shall be in accordance with ASTM A48, Class 25 minimum.
- B. All boxes shall have an outside ledge under the top ring.
- C. Top outside slip pipe shall not have flange at bottom.
- D. Valve boxes shall comply with Fairfax Water standard details.
- E. The manufacturer identification and country of origin, if other than U.S., shall be cast into all parts
- F. Minimum weights shall be as follows:
  - Cover 12.5 lbs.
  - Upper Section 37.5 lbs.
  - Lower Section 47.0 lbs.

### PART 2 – PRODUCTS

#### **Manufacturers**

#### **Approved Manufacturer(s):**

- A. Bingham & Taylor - Fig. 4908
- B. R.B. Argawalla (India)/Capitol Foundry
- C. Creswell Trading Company - Model A-1 (India)
- D. EJ - Only product numbers 85557126U, 85556036U & 85556518U
- E. Sigma Corporation
- F. Star Pipe Products - Model VBFAIRFAXW

END OF SECTION

Revised: 1/23/2018



**IFB 19-59  
Attachment 3**

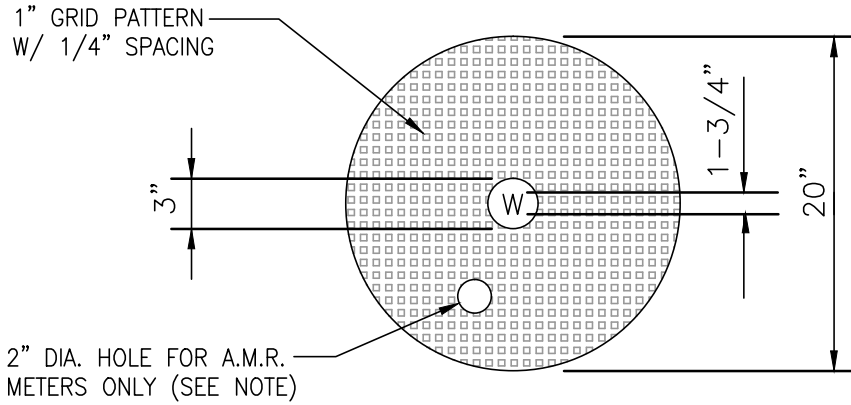

**TOP VIEW**

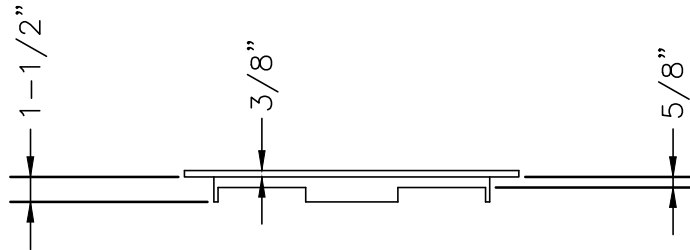

**SIDE VIEW**

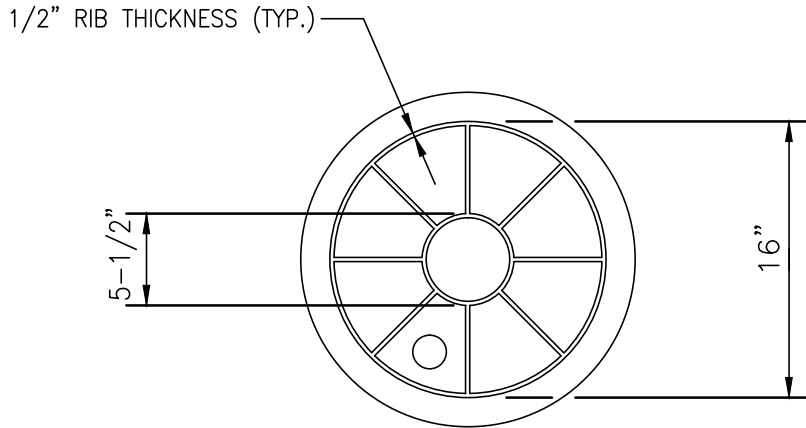

**BOTTOM VIEW**

**NOTE:**  
INSTALL 2" DIAMETER HOLE BETWEEN RIBS FOR AUTOMATIC METER READING METERS  
WHERE INDICATED ON THE PLANS OR BY FAIRFAX WATER.



**FAIRFAX WATER  
STANDARD DETAILS**

SCALE:  
NOT TO SCALE

**CAST IRON METER BOX COVER**

DRAWING NO.:

**4**

DATE: 7/17

# IFB 19-59 Attachment 3

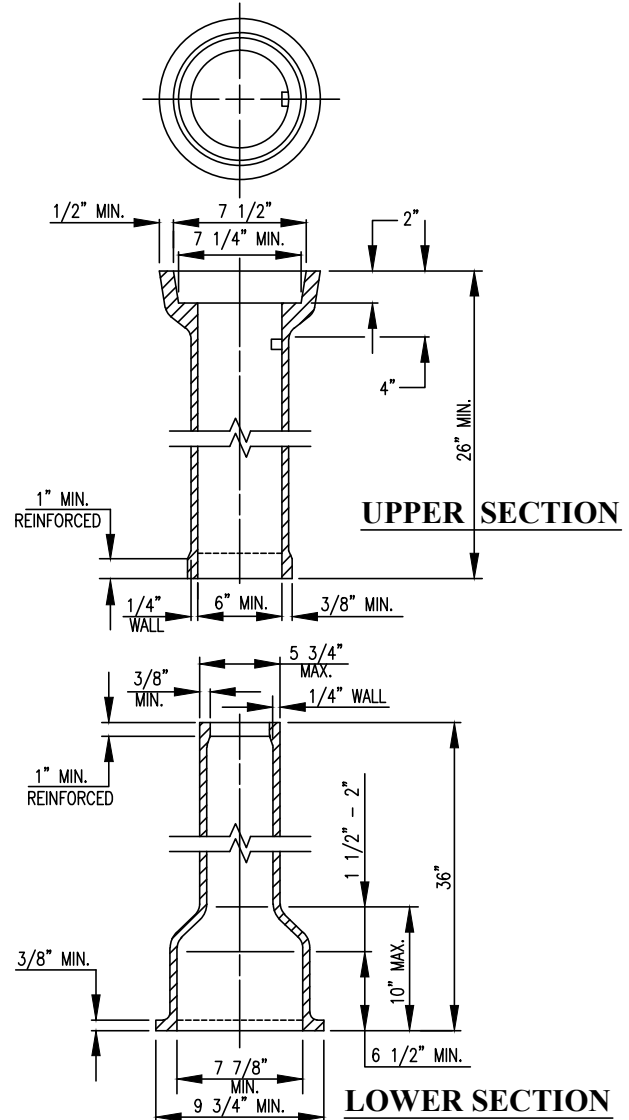
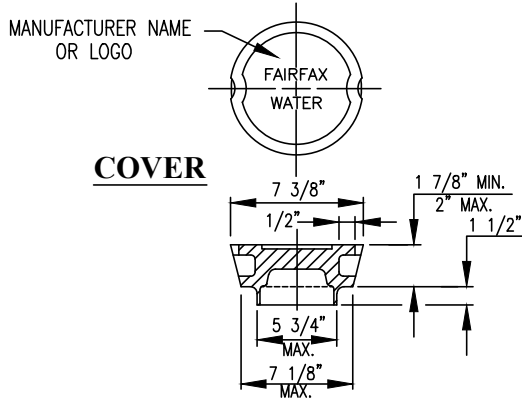

**NOTES:**

1. THE MANUFACTURER IDENTIFICATION AND COUNTRY OF ORIGIN (IF OTHER THAN U.S.) SHALL BE CAST INTO ALL PARTS.
2. GUARD POSTS ARE NOT TO BE INSTALLED AT VALVES UNLESS INDICATED ON DRAWINGS, OR AS SPECIFIED BY FAIRFAX WATER.
3. VALVE BOX MUST MEET SPECIFICATIONS CONTAINED IN FAIRFAX WATER'S APPROVED PRODUCTS LIST.
4. FOR VALVE BOXES DEEPER THAN SIX FEET, USE 5-INCH DIAMETER GRAY CAST IRON (SOIL) PIPE TO EXTEND STANDARD TOP AND BOTTOM SECTIONS.
5. STACKING OF VALVE BOX SECTIONS IS NOT ACCEPTABLE.

	<b>FAIRFAX WATER STANDARD DETAILS</b>	SCALE: NOT TO SCALE
	<b>VALVE BOX</b>	DRAWING NO.:  <span style="font-size: 1.5em;">27</span>
DATE: 7/17		