

## **AGREEMENT FOR SERVICE**

THIS AGREEMENT is effective on the 29th day of November 2023 by and between the **FAIRFAX COUNTY WATER AUTHORITY**, a political subdivision of the Commonwealth of Virginia, hereinafter referred to as "FW", and **SPECIALTY UNDERWATER SERVICES, LLC** hereinafter referred to as the "Contractor" (collectively referred to as the "parties").

### **WITNESSETH:**

In consideration of the mutual covenants set forth herein, the parties agree as follows:

The Contractor shall provide professional diver services in accordance with the following, in order of precedence: this Agreement for Service ("Agreement" or "Contract"); the Contractor's bid dated November 11, 2023 (Attachment I); and FW's Invitation For Bid dated October 10, 2023 (including all addenda) (incorporated by reference) (Attachment II). In the event that Attachments I and II contradict or limit this Agreement for Service, this Agreement shall prevail.

No representations, arrangements, understandings or agreements relating to the subject matter exist amongst the parties except as expressed in this Agreement.

### **1. TERM**

The Agreement term shall cover the period from November 29, 2023 through November 28, 2024. This Agreement may be renewed at the expiration of the initial term at the request of FW. The renewal may be for up to four (4) additional one (1) year periods. Unless otherwise agreed to by the parties or as may be required by law, any renewal shall be based on the same price structure, terms and conditions. Failure to renew by the expiration date of the then current Contract year will not automatically cancel the Contract. FW may retroactively renew the Contract at any time prior to the last day of the following Contract year providing that FW has not formally canceled the Contract.

### **2. STANDARD TERMS AND CONDITIONS**

This Agreement is subject to the following Terms and Conditions:

#### **2.1 Anti-Discrimination**

By submitting their bids, Bidders certify to FW that they will conform to the provisions of the Federal Civil Rights Act of 1964, as amended, as well as the Virginia Fair Employment Contracting Act of 1975, as amended, where applicable, the Virginians

With Disabilities Act, the Americans With Disabilities Act and §11-51 of the Virginia Public Procurement Act.

A. During the performance of the contract, the Contractor agrees as follows:

1. The Contractor will not discriminate against any employee or applicant for employment because of race, religion, color, sex, national origin, or disabilities, except where religion, sex or national origin is a bona fide occupational qualification reasonably necessary to the normal operation of the Contractor. The Contractor agrees to post in conspicuous places, available to employees and applicants for employment, notices setting forth the provisions of this nondiscrimination clause.
2. The Contractor, in all solicitations or advertisements for employees placed by or on behalf of the Contractor, will state that such Contractor is an equal opportunity employer.
3. Notices, advertisements and solicitations placed in accordance with federal law, rule or regulation shall be deemed sufficient for the purpose of meeting these requirements.

B. The Contractor will include the provisions above in every subcontract or purchase order so that the provisions will be binding upon each subcontractor or vendor.

C. Fairfax Water does not discriminate against faith-based organizations on the basis of the organization's religious character, or impose conditions that (a) restrict the religious character of the faith-based organization, except as provided by law, or (b) impair, diminish, or discourage the exercise of religious freedom by the recipients of such goods, services, or disbursements.

## **2.2 Antitrust**

By entering into a contract, the Contractor conveys, sells, assigns, and transfers to FW all rights, title and interest in and to all causes of action it may now have or hereafter acquire under the antitrust laws of the United States and the Commonwealth of Virginia, relating to the particular goods or services purchased or acquired by FW.

## **2.3 Assignment of Interest**

The Contractor shall not assign any interest in any resulting Contract and shall not transfer any interest in the same without prior written consent of FW, which FW shall be under no obligation to grant.

## 2.4 Availability of Funds

It is understood and agreed between the parties herein that FW shall be bound hereunder only to the extent of the funds available or which may hereafter become available for the purpose of this agreement.

## 2.5 Contract Changes / Change Orders

A. No verbal agreement or conversation with any officer, agent or employee of FW either before or after the execution of any Contract resulting from this solicitation or follow-on negotiations, shall affect or modify any of the terms, conditions, specifications, or obligations contained in the solicitation, or resulting Contract. No alterations to the terms and conditions of the Contract shall be valid or binding upon FW unless made in writing and signed by the purchasing contact identified on the cover page. Contract changes shall be in writing and shall be on official FW Purchasing Department letterhead. In any event and in all circumstances, the Contractor shall be solely liable and responsible for any Contract changes, deviations, etc., made without first receiving written authorization to deviate from the Contract by the FW Project Manager.

B. Changes can be made to the contract in any of the following ways:

1. The parties may agree in writing to modify the scope of the contract. An increase or decrease in the price of the contract resulting from such modification shall be agreed to by the parties as a part of their written agreement to modify the scope of the contract.
2. FW may order changes within the general scope of the contract at any time by Notice to the Contractor. Changes within the scope of the contract include, but are not limited to, things such as services to be performed, the method of packing or shipment, and the place of delivery or installation. The Contractor shall comply with the notice upon receipt. The Contractor shall be compensated for any additional costs incurred as the result of such order and shall give FW a credit for any savings. Said compensation shall be determined by one of the following methods:
  - a. By mutual agreement between the parties in writing; or
  - b. By agreeing upon a unit price or using a unit price set forth in the contract, if the work to be done can be expressed in units, and the Contractor accounts for the number of units of work performed, subject to FW's right to audit the Contractor's records and/or to determine the correct number of units independently; or
  - c. By ordering the Contractor to proceed with the work and keep a record of all costs incurred and savings realized. A markup for overhead and profit may be allowed if provided by the contract. The same markup shall be used for determining a decrease in price as the result of savings realized. The Contractor shall present FW with all vouchers and records of

expenses incurred and savings realized. FW shall have the right to audit the records of the Contractor, as it deems necessary to determine costs or savings. Any claim for an adjustment in price under this provision must be asserted by Notice to the Purchasing Department. Neither the existence of a claim nor a dispute resolution process, litigation or any other provision of this contract shall excuse the Contractor from promptly complying with the changes ordered by FW or with the performance of the contract generally.

## **2.6 Contractor's Responsibilities**

- A. The Contractor shall be responsible for all products and/or services as required by this agreement. The use of subcontractors is prohibited unless:
  - 1. A request to include a subcontractor is included in the bid and,
  - 2. The Bidder receives written approval to use a subcontractor prior to, or as part of the formal contract between the parties.
- B. Even when properly authorized by FW, the use of a subcontractor does not relieve the Contractor of liability under the contract.
- C. The Contractor, at its sole expense, shall be responsible for damage to FW and non-FW property as a result of its failure, or its subcontractor's failure to protect such facilities and utilities.
- D. The Contractor, at its sole expense, shall immediately repair or replace FW property damaged by (or caused by) the Contractor or its Subcontractor(s). Replacements will be of equal or better quality than the property damaged property, and all such work must be approved by FW Project Manager.

## **2.7 Ethics in Public Contracting**

Contractor hereby certifies that it has familiarized itself with Article 4 of Title 11 of the Virginia Public Procurement Act, Section 11-72 through 80, Virginia Code Annotated, and that all amounts received by it, pursuant to a contract resulting from this solicitation, are proper and in accordance therewith.

## **2.8 Examination of Records**

Bidder agrees that in any resulting contract, either FW or its duly authorized representative shall have access to and the right to examine and copy any directly pertinent books, documents, papers, and records of the Contractor involving transactions related to any resulting contract. This obligation shall expire five years after the final payment for the final service performed as a result of any and all contract(s) awarded pursuant to this solicitation, or until audited by FW, whichever is sooner. Contractor will provide reasonable access to any and all necessary documents and upon demand provide copies of documents if so required by FW or

its representative(s). FW will reimburse the Contractor for any reasonable expenses it incurs as a result of such a request.

## **2.9 Governing Law; Venue; Waiver of Jury Trial**

Notwithstanding any provision to the contrary, this solicitation and any resulting contract shall be governed in all respects by the laws of the Commonwealth of Virginia. Any dispute arising hereunder which is not otherwise resolved by the parties shall be resolved by a court of competent jurisdiction in the Commonwealth of Virginia. The Contractor and FW hereby waive any right such party may have to a trial by jury in connection with any such litigation.

## **2.10 Indemnification and Responsibility for Claims and Liability**

With respect to any contract that results from this solicitation, Bidder is bound by the following:

- A. The Contractor shall indemnify, save harmless and defend FW, or any employee of FW, against liability for any suits, actions, or claims of any character whatsoever arising from or relating to the performance of the Contractor or its subcontractors under this contract.
- B. FW has no obligation to provide legal counsel or defense, or pay attorney's fees to the Contractor or its subcontractors in the event that a suit or action of any character is brought by any person not party to the contract, against the Contractor or its subcontractors as a result of or relating to the Contractor's obligations under this contract.
- C. FW has no obligation for the payment of any judgments or the settlement of any claims against the Contractor or its subcontractors as a result of or relating to the Contractor's obligations under this contract.
- D. The Contractor shall immediately notify FW of any claim or suit made or filed against the Contractor or its subcontractors regarding any matter resulting from or related to the Contractor's obligations under the contract. If such a claim or suit is brought, the Contractor will cooperate, assist, and consult with FW in the defense or investigation of any suit or action made or filed against FW as a result of or relating to the Contractor's performance under this contract.
- E. The Contractor shall pay all royalties and license fees necessary for performance of the contract. The Contractor shall defend all suits or claims for infringement of any patent rights or other proprietary rights arising from or related to performance of the resulting contract and shall save FW harmless from any loss, including Attorneys' fees arising out of any such claim.

## 2.11 Insurance

- A. In addition to the mandatory insurance requirements listed in this Section and, at the request of FW, any Bidder may be required to provide a list of all insurance claims made against it within the past 36 months. FW reserves the right to reject any bid if in FW's opinion the amount or number of claims is deemed to be excessive. A Bidder's failure to comply with this requirement may result in rejection of its bid. If no claims have been made, then the Bidder shall so state in its bid. Fairfax Water may require such information from the Contractor as it deems necessary to assess the Contractor's financial ability to pay any deductibles with respect to the insurance policies required hereunder.
- B. Before commencing the work, the Contractor shall procure and maintain at its own expense, minimum insurance in forms and with insurance companies acceptable to FW to cover loss or liability arising out of the Work. All insurance policies must be underwritten by insurers authorized to conduct business within the Commonwealth of Virginia and must have a Best's rating of at least A- and a financial size of class VIII or better in the latest edition of Best's Insurance Reports.
- C. The Contractor shall immediately notify FW of any claim or suit made or filed against the Contractor or its subcontractors regarding any matter resulting from or related to the Contractor's obligations under the contract. If such a claim or suit is brought, the Contractor will cooperate, assist, and consult with FW in the defense or investigation of any suit or action made or filed against FW as a result of or relating to the Contractor's performance under this contract.
- D. With the exception of Workers' Compensation and Employers' Liability Insurance, all additional insurance policies specified herein shall name FW as an additional insured with regard to work performed under any subsequent Contract
- E. The Contractor will provide FW with copies of certificates of insurance coverage and proof of payment of all premiums. Each certificate of insurance must include:
  - (a) an endorsement from the insurer that certifies that the Contractor maintains the referenced policy in full force and effect;
  - (b) where applicable, a statement indicating that FW is included as an additional insured; and
  - (c) a provision requiring that not less than 30 days written notice will be given to FW before any policy or coverage is canceled or modified in any material respect. Without limiting the requirements set forth above, the insurance coverages will include a minimum of:
    - 1. Workers' Compensation and Employers' Liability Insurance: Statutory requirements and benefits as required by the Commonwealth of Virginia; and

2. Required Commercial General Liability Insurance: This insurance must be written on an "occurrence" basis and shall be endorsed to include FW as an additional insured and shall provide at a minimum the following:

- ◆ General Aggregate Limit \$1,000,000  
(Other than Products-Completed Operations)
- ◆ Products-Completed Operations Aggregate Limit \$ 500,000
- ◆ Personal & Advertising Injury Limit \$ 500,000
- ◆ Each Occurrence Limit \$ 500,000

F. Business Automobile Liability Insurance: This insurance coverage must extend to any motor vehicles or other motorized equipment regardless of whether it is owned, hired, or non-owned and must cover Bodily Injury and Property Damage with a combined single limit of at least \$1,000,000 each accident. This insurance must be written in comprehensive form and must protect the Contractor and FW against claims for injuries to members of the public and/or damage to the property of others arising from the Contractor's use of motor vehicles or other equipment and must cover both on-site and off-site operations.

G. Nothing contained herein will be deemed to operate as a waiver of FW's sovereign immunity under the law.

## 2.12 No Waiver or Estoppel

Neither the inspection by FW nor any of its employees, nor any payment of money, nor payment for, nor acceptance of any Commodity by FW, nor any extension of time shall operate as a waiver of any provision of this Contract, or of any power herein reserved to the Owner or of any right to damage herein provided. No waiver of any breach of this Contract shall be held to be a waiver of any other subsequent breach. All remedies provided in this Contract to FW shall be construed as cumulative and shall be in addition to each and every other remedy herein provided. Neither FW, nor any officer, employee, or authorized representative of FW, will be bound, precluded, or estopped by any action, determination, decision, acceptance, return, certificate, or payment made or given under or in connection with the Contract by any officer, employee or authorized representative of the Owner, at any time either before or after final completion and acceptance of the Work and payment therefore from: (a) showing the true and correct classification, amount, quality, or character of the Commodities delivered, or that any determination, decision, acceptance, return certificate or payment was incorrect or was improperly made in any respect, or that the Commodities or any part thereof do not in fact conform to the requirements of the Contract; (b) demanding and recovering from the Contractor any overpayment made to the Contractor or such damages as FW may sustain by reason of the Contractor's failure to comply with the requirements of the Contract; or (c) both of the foregoing clauses (a) and (b).

## 2.13 Payment Clauses Required in All Contracts

Section § 2.2-4352 of the Virginia Public Procurement Act requires the following:

- A. That any contract awarded by FW include the following clauses:
1. The Contractor shall take one of the two following actions within seven days after receipt of amounts paid to the contractor by FW for work performed by any subcontractor(s) under the contract:
    - a. The Contractor shall pay its subcontractor(s) for the proportionate share of the total payment received from FW attributable to the work performed by the subcontractor under that contract; or
    - b. Notify FW and any subcontractor(s), in writing, of his intention to withhold all or a part of the subcontractor's payment with the reason for nonpayment.
  2. Bidders shall include in their offer submissions either: (i) if an individual contractor, their social security numbers; and (ii) proprietorships, partnerships, and corporations to provide their federal employer identification numbers.
  3. The contractor shall pay interest to the subcontractor(s) on all amounts owed by the Contractor that remain unpaid after seven days following receipt by the Contractor of payment from FW for work performed by the subcontractor under the contract, except for amounts withheld as allowed in subdivision 1.
  4. Unless otherwise provided under the terms of this contract, interest shall accrue at the rate of one percent per month.
- B. The contractor shall include in each of its subcontracts a provision requiring each subcontractor to include or otherwise be subject to the same payment and interest requirements with respect to each lower-tier subcontractor.
- C. A contractor's obligation to pay an interest charge to a subcontractor pursuant to the payment clause in this section shall not be construed to be an obligation of FW. A contract modification shall not be made for the purpose of providing reimbursement for the interest charge. A cost reimbursement claim shall not include any amount for reimbursement for the interest charge.

## 2.14 Payment

- A. Invoices: All invoices are to be sent directly to FW Accounts Payable department by mail, fax, or e-mail. Invoices shall include the FW Purchase Order / Contract number and the contractor's FEIN. Invoices are not to be sent to the contract Project Manager, or other departmental reps. Failure to comply may result in late payments for which FW will not be liable.

- B. Terms: All payments will be Net 30 from the date of receipt of a valid invoice at FW Finance Department. Payment terms requiring payment in less than 30 days will be regarded as requiring payment 30 days after invoice or delivery, whichever occurs last. This shall not affect offers of discounts for payment in less than 30 days, however.
- C. Partial Payments: Requests for partial payments or advanced payments must be submitted as part of the Price Bid along with a justification. FW reserves the right to accept, reject or negotiate requests for partial payments. If the request is rejected, the Bidder must waive the requirement in order to remain in consideration.
- D. Refunds: If the Contractor is declared to be in default, FW will be eligible for a full and immediate refund for all payments made to the Contractor. Partial Payments: Requests for partial payments or advanced payments must be submitted as part of the Price Offer along with a justification. FW reserves the right to accept, reject or negotiate requests for partial payments. If the request is rejected, the Bidder must waive the requirement in order to remain in consideration.
- E. Unreasonable Charges: Under certain emergency procurements and for most time and material purchases, final job costs cannot be accurately determined at the time orders are placed. In such cases, final payment is contingent on a determination of reasonableness with respect to all invoiced charges. Charges that appear to be unreasonable will be researched and challenged, and that portion of the invoice held in abeyance until a settlement can be reached. Upon determining that invoiced charges are not reasonable, FW shall promptly notify the Contractor, in writing, as to those charges that it considers unreasonable and the basis for the determination.

## **2.15 Price Firm Period**

Pricing shall be firm and fixed as originally offered and accepted for the first 12 months of the contract.

## **2.16 Annual Economic Price Adjustment**

- A. The Contractor may submit a request for contract price increases once annually for each renewal year. Economic increases shall be limited to the increase specified in the Bureau of Labor Statistics for the 12-month period ending 90 days prior to the end of the then current contract year.
- B. For services: Annual rate increases will be based on the Consumer Price Index-U (CPI-U), Washington-Arlington-Alexandria.

- C. Negative BLS index: If the agreed upon index is a negative number the Contractor shall reduce contract rates by the same amount for new contract year.

## **2.17 Taxes**

FW is exempt from Federal Excise Taxes, Virginia State Sales and Use Taxes, and the District of Columbia Sales Taxes and Transportation Taxes. FW's tax identification number is 54-6025290.

## **2.18 Termination of Contract**

- A. For Cause. In the event that the Contractor: (1) fails to deliver any Commodity or Service in accordance with the time period established therefore in the Contract; or (2) fails to furnish any Commodity or Service which conforms in all respects to the requirements of the Contract; then FW, without prejudice to any other rights or remedies it may have at law or in equity (including its right to seek damages from the Contractor), shall have the right to terminate the Contract and any outstanding Purchase Orders by issuing a written notice of termination to the Contractor. Such notice of termination shall describe in reasonable detail the grounds for the termination and shall take effect immediately upon receipt by the Contractor.

If, after issuance of a notice of termination under this Section it is determined for any reason that cause for such termination did not exist, then the rights and obligations of the parties shall be the same as if the notice of termination had been delivered under the provisions of subsection B (termination for convenience) hereof; provided, however, that the Contractor in such event shall be deemed to have received seven days prior written notice of such termination. Any compensation due the Contractor pursuant to subsection B shall be offset by the cost to FW of remedying the default by the Contractor. The Contractor shall in no event be entitled to receive any consequential damages or any anticipated profits with respect to Commodities not yet furnished to, and accepted by, FW as of the effective date of any such termination.

- B. For Convenience. FW shall have the right to terminate the Contract and/or any outstanding Purchase Orders issued hereunder at its own convenience for any reason by giving seven business days prior written notice of termination to the Contractor. In such event, the Contractor shall be paid an amount equal to the actual cost of any Commodity delivered to, and accepted by, FW and the actual cost of any equipment, goods or materials ordered by the Contractor hereunder in good faith which could not be canceled, less the salvage value thereof, provided sufficient substantiation is furnished to FW. Any subcontract entered into by the Contractor in connection with the transactions contemplated hereby shall contain a similar termination provision for the benefit of the Contractor and FW. The Contractor shall in no event be entitled to receive anticipated profits on any Commodities not yet furnished to and accepted by FW as of the effective date of any such termination.

## **2.19 Virginia Freedom of Information Act**

Except as provided herein, all proceedings, records, contracts and other public records relating to procurement transactions shall be open to the inspection of any citizen, any interested person, firm, or corporation, in accordance with the Virginia Freedom of Information Act.

## **2.20 Faith-Based Organizations**

Non-Discrimination by FW. FW represents and warrants that it does not discriminate against faith-based organizations.

## **2.21 No Employment of Unauthorized Aliens**

CONTRACTOR hereby covenants and agrees that it does not, and shall not during the term of this MSA, knowingly employ an unauthorized alien (as such term is defined in the federal Immigration Reform and Control Act of 1986).

## **2.22 Severability**

In the event that any provision shall be adjudged or decreed to be invalid by a court of competent jurisdiction, such ruling shall not invalidate the entire Agreement but shall pertain only to the provision in question and the remaining provisions shall continue to be valid, binding and in full force and effect.

## **2.23 Licensure**

To the extent required by the Commonwealth of Virginia (see e.g. 54.1-1100 et seq. of the Code of Virginia) or FW, the Contractor shall be duly licensed to provide the goods and services required to be delivered pursuant to this Contract.

## **2.24 Authorization to Transact Business in Virginia**

CONTRACTOR hereby represents and warrants as follows: (a) it is authorized to transact business in the Commonwealth of Virginia as a domestic or foreign business entity if so required by Title 13.1 or Title 50 of the Virginia Code, or as otherwise required by law; and (b) it shall not allow its existence to lapse or its certificate of authority or registration to transact business in Virginia, if so required under Title 13.1 or Title 50 of the Virginia Code, to be revoked or cancelled at any time during the term of this Agreement.

## **2.25 Right of Audit**

CONTRACTOR covenants and agrees to retain all books, records and other documents (electronic or otherwise) relating this MSA (the "Project Records") for at least five (5) years after final payment hereunder. Project Records will be deemed to exclude books, records and other documents if and to the extent they are protected by the attorney-client privilege. FW and its authorized agents (the "Auditing Parties") shall have full access to and the right to examine the Project Records upon written request at any time, and from time to time, during the term of this MSA and for a period of five (5) years thereafter. CONTRACTOR hereby covenants and agrees that, within 10 days after it receives written notice from an Auditing Party, it will make the Project Documents available for inspection and copying by such Auditing Party during CONTRACTOR's regular business hours, with copies being provided at a reasonable cost payable by the Auditing Party. Any failure on the part of CONTRACTOR to comply with the provisions of this Section will constitute a breach of the MSA and, regardless of whether such failure occurs during the term of the MSA, or within the five year period commencing on the date of final payment hereunder, will constitute sufficient grounds for debarment of CONTRACTOR. CONTRACTOR hereby agrees that it will pay and be responsible for all costs and expenses (including court costs and attorneys' fees) incurred by an Auditing Party in enforcing this provision.

## **2.26 Drug-free Workplace to be Maintained by Contractor**

During the performance of this contract, the agrees to (i) provide a drug-free workplace for CONTRACTOR's employees; (ii) post in conspicuous places, available to employees and applicants for employment, a statement notifying employees that the unlawful manufacture, sale, distribution, dispensation, possession, or use of a controlled substance or marijuana is prohibited in CONTRACTOR's workplace and specifying the actions that will be taken against employees for violations of such prohibition; (iii) state in all solicitations or advertisements for employees placed by or on behalf of CONTRACTOR that CONTRACTOR maintains a drug-free workplace; and (iv) include the provisions of the foregoing clauses in every subcontract or purchase order of over \$10,000, so that the provisions will be binding upon each subcontractor, subconsultant, or vendor. For purposes hereof, a "drug-free workplace" shall mean the site for the performance of the Work contemplated hereby.

## **2.27 Non-Discrimination by CONTRACTOR**

CONTRACTOR covenants and agrees as follows:

- (a) During the Term, CONTRACTOR will not discriminate against any employee or applicant for employment because of race, religion, color, sex, or national origin, except where religion, sex or national origin is a bona fide occupational qualification reasonably necessary to the normal operation of CONTRACTOR. CONTRACTOR agrees to post in conspicuous places, available

to employees and applicants for employment, notices setting forth the provisions of this nondiscrimination clause.

(b) CONTRACTOR, in all solicitations or advertisements for employees placed by or on behalf of CONTRACTOR, will state that CONTRACTOR is an equal opportunity employer.

(c) Notices, advertisements, and solicitations placed in accordance with federal laws, rules, or regulations shall be deemed sufficient for the purpose of meeting the requirements of this Section.

CONTRACTOR will include the provisions of the foregoing Sections (a), (b), and (c) in every subcontract, sub consulting agreement, and purchase order over \$10,000, in order that the provisions above will be binding upon each subcontractor, subconsultant, and vendor.

## **2.28 Payment to Subcontractors and Subconsultants.**

Within seven days after receipt of each payment for services provided hereunder, CONTRACTOR shall:

(a) pay each subcontractor and/or subconsultant an amount equal to the percentage of the Services attributable to such subcontractor or subconsultant; or

(b) notify FW and each such subcontractor and/or subconsultant in writing of the intention to withhold all or part of the amounts due such subcontractor or subconsultant and state the reason for such nonpayment.

CONTRACTOR shall pay interest on amounts owed to any subcontractor and/or subconsultant which remain unpaid seven days after CONTRACTOR's receipt of payment for services provided hereunder, provided, however, that amounts owed any subcontractor and/or subconsultant which have been withheld properly pursuant to this Section, shall not accrue interest. Interest on amounts due any subcontractor and/or subconsultant and unpaid shall accrue at the rate of one-half of one percent (1%) per month; provided, however that CONTRACTOR's obligation to pay interest hereunder shall in no event be construed to be an obligation of FW. No contract modification shall be made, and no cost reimbursement claim shall be submitted, for purposes of reimbursement for the interest charge. CONTRACTOR shall include in each of its subcontracts a provision requiring each of its subcontractors and/or subconsultants to include or otherwise be subject to the same payment and interest requirements with respect to each lower tier subcontractor and/or subconsultant.

## **2.29 Counterparts**

This AGREEMENT and any amendments or renewals hereto may be executed in a number of counterparts, and each counterpart signature, when taken with the other counterpart signatures, is treated as if executed upon one original of this Contract or any amendment or renewal. A signature by any party to this Contract provided by facsimile or electronic mail is binding upon that party as if it were the original.

## **2.30 Non-Waiver**

No waiver of any provision of this agreement shall constitute a waiver of any other provision nor shall any waiver of this Agreement constitute a continuing waiver unless otherwise expressly provided.

## **2.31 Dispute Resolution Process**

Contractual claims, whether for money or for other relief, will be submitted in writing to FW not later than 60 days after final payment; provided however, that written notice of CONTRACTOR's intention to file such claim must:

- a. be delivered to the attention of FW's Procurement Manager, at the address shown in the notice provisions of the MSA, not later than five days after the occurrence or of the beginning of the Work upon which the claim is based; and
- b. contain a reasonably detailed description of the basis of the claim.

CONTRACTOR's failure to comply with the foregoing requirements will result in waiver of the claim. FW will make a written decision upon any such claim within 60 days after submittal of the claim. CONTRACTOR will not institute legal action prior to receipt of FW's decision on the claim unless FW fails to render such decision within 90 days after submittal of the claim. The decision of FW will be final, unless CONTRACTOR initiates legal action as provided in § 2.2-4364 of the Virginia Code. Failure of FW to render a decision within 90 days will not result in CONTRACTOR being awarded the relief claimed, nor will it result in any other relief or penalty. The sole result of FW's failure to render a decision within the time allotted will be CONTRACTOR's right to immediately institute legal action. No administrative appeals procedure pursuant to § 2.2-4365 of the Virginia Code has been established for contractual claims under this AGREEMENT.

## **3. SPECIAL TERMS AND CONDITIONS**

### **3.1 Contractor's Compliance and Safety Program**

- A. The Contractor shall comply with all applicable Federal, State, and local safety programs, regulations, standards, and codes, to include though not limited to:
  1. The Virginia Uniform Statewide Building Code,

2. Building Officials & Code Administrators (BOCA) codes (together with adopted International Codes),
  3. Virginia Department of Health (VDH) regulations,
  4. Virginia Department of Environmental Quality (DEQ) regulations,
  5. Virginia-OSH (VOSH) regulations, and
  6. National Electric Code (NEC).
- B. The Contractor shall have a written safety program that complies with all applicable OSHA and VOSH standards for General Industry regulations and a written Permit Required Confined Space Entry Program that complies with the then current VOSH Standard Confined Space Entry Standard. A copy of these programs shall be provided to FW with the Contractor's general safety program not later than seven days after contract award and before beginning work.
- C. When working in a confined space, the Contractor shall utilize only personnel trained for confined space entry and shall provide all entry equipment including atmospheric test equipment.
- D. Hard Hat Area: Contractor's employees shall wear hard hats while working outdoors at the work site.

### **3.2 Contractor's Responsibilities**

- A. The Contractor shall be responsible for all products and/or services as required by this solicitation. The use of subcontractors is prohibited unless:
1. A request to include a subcontractor is included in the proposal and,
  2. The Bidder receives written approval to use a subcontractor prior to, or as part of the formal contract between the parties.
- B. Even when properly authorized by FW, the use of a subcontractor does not relieve the Contractor of liability under the contract.
- C. The Contractor, at its sole expense, shall be responsible for damage to FW and non-FW property as a result of its failure to protect such facilities and utilities.
- D. Where the Contractor's Work may cause damage or disrupt existing FW property including but not limited to utilities, plant equipment, instrumentation and control systems, etc. the Contractor shall make all necessary arrangements for the protection of such property. The Contractor, at its sole expense, shall immediately replace FW property removed or damaged by, or at the direction of, the Contractor or any Subcontractor to the Contractor. Replacements will be new and current technology unless otherwise provided for in these specifications or authorized by the FW Project Manager.
- E. Contractor shall return all work areas to the same or better condition than prior to start of Work. Contractor must notify the FW Project Manager of any area, piece

of equipment, etc., that is damaged or not in the same or better condition than prior to start of Work. The Contractor will be responsible for repair, replacement, etc., of any such property, which is within the Contractor's area of responsibility and is found to be in need of repair/service by the FW Project Manager. Acceptance shall not occur until all such damages are either repaired or replaced or for which FW is reimbursed a fair and reasonable sum as negotiated and agreed to in writing, by the FW Project Manager.

### **3.3 Delays**

- A. By the Contractor: After prior written warning to the Contractor, FW may declare the Contractor in default for unacceptable delays. If such a declaration is made, FW reserves the unilateral right to cure the default by any means available to FW, including (but not limited to) liquidated damages, redeeming the Contractor's Performance Bond (or other security as agreed to by FW prior to contract award); and to recover any additional costs, lost funds and/or related expenses. This is not a limitation of FW's legal rights to recover damages due to Contractor default in any other way.
  
- B. By FW: The Contractor shall not be responsible for delays caused by FW, its agents, or other Contractors. To the extent that the Contractor is unable to proceed due to the actions or inaction's of FW, its agents, employees or other Contractors, the Contractor shall be granted an extension to the installation schedule equal to the documented amount of time the Contractor was prevented from performing work. The Contractor shall not be eligible for damages as a result of FW delays.

### **3.4 Force Majeure**

If a delivery is delayed by Act of God, terrorism, war, embargo, fire, or explosion not caused by the negligence or intentional act of the Contractor or his subcontractors or supplier(s), a reasonable extension of time as FW or the Member deems appropriate may be granted. Upon receipt of a written request and justification for any extension from the Contractor, FW or the Member may in its sole discretion (i) extend the time for delivery of the Commodity; (ii) suspend the Contract in whole or in part and obtain one or more of the Commodities elsewhere for a time, or (iii) terminate the Contract; all without liability to Contractor on the part of FW or Member, as the case may be. Contractor's request and justification shall be subject to such substantiation and further inquiries as FW or Member may require.

### **3.5 Inspection of Job Site**

- A. Pre-Existing Conditions: By submitting an offer in response to this solicitation, Bidder agrees that it will perform a diligent site tour. Bidders confirm that the price elements contained in its financial proposal reflect any and all conditions

under which the work must be accomplished. After contract award, any claim based upon conditions that the Contractor should reasonably have discovered during the site survey will not be considered by FW.

- B. Changes to Existing Conditions: Contractor shall promptly notify the Project Manager or his designee of any site changes that may affect the Project as soon as such changes are discovered. Work in the affected area shall be halted until the Project Manager or his designee inspects the newly discovered condition. To the extent that such changes affect the scope of the contract, the Contractor shall submit a written proposal for any work necessary to complete the Project. Such proposals shall be submitted within ten days of discovery and shall include a detailed listing of all additional price changes to FW.

### **3.6 Priority Customer**

By submitting a Bid in response to this solicitation, Bidder understands and acknowledges that FW provides services that are essential to the health and welfare of the public. To the extent that the Contractor must prioritize and/or allocate services among its customers, the requirements of FW will be honored before service is provided to a customer with no obligations with regard to the public health and welfare.

### **3.7 Site Safety and Access**

- A. The Contractor shall schedule and coordinate the Work and install temporary facilities as required to maintain continuous operation and access to existing equipment in the area of Work. The Contractor shall not commence retrofit work until authorized by the FW Project Manager. The Contractor is advised that FW may, at its sole discretion, delay or stop work as required to ensure continuous and reliable operation of the facility, especially during peak flow events.
- B. The Contractor shall secure the Site and all areas of Work to prevent access and the potential for injury to its employees, FW employees, its agents, and others by construction and installation of temporary guard-rails, fencing, barricades, highway cones, warning signs/tape, etc., and/or other appropriate means, and as directed by the FW Project Manager. Such hazards include but are not limited to mechanical hazards, electrical hazards, surface irregularities or construction tools and equipment.
- C. FW shall have the right to deny access to the Site, or require the Contractor to remove from the Site, any individual who has exhibited violent, abusive, or threatening behavior or conduct.
- D. FW may limit, restrict, or prohibit access to areas of the Site on a permanent or temporary basis. When access to such restricted areas is required by the Contractor to perform the Work, the Contractor shall obtain permission from the

FW Project Manager and shall comply with such conditions or limitations to access as may be imposed by the FW Project Manager.

- E. FW may restrict parking or require parking permits for vehicles to be brought onto the plant. The Contractor shall be responsible for arranging transportation for its personnel to reach the job sites from whatever parking area is provided by FW.

### **3.8 Superintendence by Contractor**

- A. The Contractor shall have a competent Field Supervisor, satisfactory to FW, on the job site at all times during the progress of the Work. The Contractor shall be responsible for coordinating all portions of the Work under contract except where otherwise specified in the contract documents, and for all safety and worker health programs and practices. The Contractor shall notify the Project Manager, in writing, of any proposed change in superintendent including the reason therefore prior to making such change.
- B. The Contractor shall at all times enforce strict discipline and good order among the workers on the project. The Contractor shall not employ on the Project any unfit person, anyone not skilled in the work assigned to him, or anyone who will not work in harmony with those employed by the Contractor, subcontractors, FW or FW's separate Contractors and their subcontractors.
- C. FW may, in writing, require the Contractor to remove from FW property, any employee FW deems to be incompetent, careless, not working in harmony with others on the site, or otherwise objectionable.

### **3.9 Time Is Of The Essence**

**This is a time critical project!** Once started, this project must continue without delay or interruption, and unauthorized delays by the Contractor are prohibited. After prior written warning to the Contractor, FW may declare the Contractor in default for unacceptable delays. If such a declaration is made, FW reserves the unilateral right to cure the default by obtaining the services of a qualified Contractor to complete the project and charge any additional or increased costs to the Contractor.

## **4. COMPENSATION**

See Attachment I.

**[SIGNATURES ON FOLLOWING PAGE]**

**FAIRFAX COUNTY WATER AUTHORITY**

8570 Executive Park Avenue  
Fairfax, VA 22031

Phone: (703) 289-6265

**SPECIALTY UNDERWATER  
SERVICES, LLC**

35 Stahl Point Road  
Baltimore, MD 21226

Phone: (443) 812-9482

By: Elizabeth B. Dooley, CPPO, CPPB

Digitally signed by Elizabeth B. Dooley,  
CPPO, CPPB  
DN: cn=Elizabeth B. Dooley, CPPO,  
CPPB, o=US, ou=Fairfax Water Authority,  
ou=Finance - Procurement,  
email=edooley@fairfaxwater.org  
Date: 2023.11.30 16:27:00 -0500

Name: Elizabeth B. Dooley, CPPO, CPPB

Title: Procurement Manager

Date: \_\_\_\_\_

By: Sally A. Gloeckl

Name: Sally A. Gloeckl

Title: Executive Vice President

Date: November 30, 2023

**IFB 23-067**

**Commercial Diver Services to Clean Potomac River Offshore, and Onshore Intakes**

**ATTACHMENT 1  
BID SUBMISSION FORM**

COMPANY NAME: SUS LLC

ADDRESS: 35 STAHL POINT ROAD, BALTIMORE MD 21226

CONTACT PERSON: LUCAS BROWNING

TELEPHONE: 443-812-9482 E-MAIL: L\_BROWNING@SUSDIVERS.COM

FAX: \_\_\_\_\_ FED ID #: 20-0647605

Pursuant to Title 13.1 or Title 50 of the Virginia Code provide the identification number issued to your firm by the Virginia State Corporation Commission (VSCC) in the space provided below. If your firm is not required to be authorized to transact business under Title 13.1 or Title 50, or any other law; provide a statement why your firm is not required to be so authorized.

SPECIALTY UNDERWATER SERVICES T0568859

Company Name Identification Number

If you do not have a VSCC identification number, explain why it is not required in the space below:

\_\_\_\_\_  
\_\_\_\_\_  
\_\_\_\_\_

Item No.	Item Description	Quantity	Unit	Unit Price	Total Cost/ Item
1	Base Proposal (Mobilization & Setup)	1	Lump Sum	N/A	\$ 9,570.00
2	Offshore Intake Work Tasks (See Section 2.2 A.) (Total Cost Per Foot Based on Average Depth per Quadrant)	4	Feet	\$8,972.00	\$ 35,888.00
3	Onshore Intake-Work Tasks (See Section 2.2 B)	1	Lump Sum	N/A	\$21,533.00
4	<b>TOTAL AMOUNT PROPOSED</b> (Items 1 through 3 inclusive)	<b>\$66,991.00</b>			

Estimated number of days to complete Item 2 8. Item 3 4.

**NOTE** – Item No. 2 shall be inclusive of all work described in Section 2.2 A. Per Section 2.2, Scope of Work, Paragraphs A.1. a, b, and c, any adjustments to the base bid price for Bid Item 2 shall be reflective of the percentage of re-cleaning that may become necessary.

**IFB 23-067**  
**Commercial Diver Services to Clean Potomac River Offshore, and Onshore Intakes**

**ATTACHMENT I**  
**BID SUBMISSION FORM**

\*All bids are to be quoted as FOB Destination. Include all necessary costs in your quote submission (see above). Failure to include the cost of mobilization and contractor overhead will be interpreted as included in the unit price for each item. FW will not pay for any additional charges not included in your bid.

- **TERMS:** \_\_\_\_\_ All bids will be interpreted as Net 30 unless otherwise specified herein. FW's minimum payment term is Net 30 days. By submitting an offer to sell in response to this solicitation, all bidders acknowledge and agree to this requirement.

By my signature I certify that I am acting as an agent or in the case of an LLP, the Partner or Managing Partner for the firm identified below and I am fully authorized to bind the firm to the terms, conditions and specifications of this solicitation, as well as any addenda thereto.

Company Name: SPECIALTY UNDERWATER SERVICES LLC

Signature: 

Printed Name: SALLY GLOECKL

Title: VICE PRESIDENT Date: 11/10/2023



MORIN BUILDING  
8570 EXECUTIVE PARK AVENUE  
FAIRFAX, VIRGINIA 22031

## INVITATION FOR BIDS

**Number:** IFB 23-067

**Requirement:** Commercial Diver Services to Clean Potomac River Offshore, and Onshore Intakes

**Date Issued:** October 10, 2023

**Optional Site Visit:** 8:30 a.m., October 17, 2023

**Deadline for Questions:** 12:00 p.m., October 20, 2023

**Bid Due Date:** 2:00 p.m., November 13, 2023

**IFB Delivery Location and Place of Bid Opening:** Procurement Department  
Fairfax Water  
8570 Executive Park Avenue  
Fairfax, Virginia 22031

**Procurement Contact:** Laurie A. Hankins, CPPB  
Procurement Specialist I  
Telephone: (703) 289-6266  
E-Mail: [lhankins@fairfaxwater.org](mailto:lhankins@fairfaxwater.org)

### Microsoft Teams meeting

Join on your computer, mobile app or room device

[Click here to join the meeting](#)

Meeting ID: 224 727 831 076

Passcode: JPZdrh

[Download Teams](#) | [Join on the web](#)

Or call in (audio only)

+1 571-348-5786,,712495381# United States, Arlington

Phone Conference ID: 712 495 381#

IFB 23-067

Commercial Diver Services to Clean Potomac River Offshore, and Onshore Intakes

**SUMMARY INFORMATION AND SUBMISSION OF BIDS**.....1

**1.0 Introduction**.....1

**1.1 Objective**.....1

**1.2 Cancellation**.....1

**1.3 Familiarity with Specifications**.....1

**1.4 Optional Pre-Bid Site Visit**.....1

**1.5 Questions and Communications**.....2

**1.6 Definitions**.....2

**1.7 Instructions for Submitting Bids**.....3

**1.8 Bid Submission Package**.....3

**1.9 Cancellation**.....4

**1.10 Proprietary Information**.....4

**1.11 Exceptions/Additions**.....4

**1.12 Addenda to the IFB**.....5

**1.13 Receipt of Addenda**.....5

**1.14 Late Bids**.....5

**1.15 Contract Award**.....5

**1.16 Term of Contract and Contract Renewal**.....5

**2.0 BID SPECIFICATIONS AND RELATED REQUIREMENTS**.....6

**2.1 Contract Requirements**.....6

**2.2 Scope of Work:**.....7

**2.3 Crew Size:**.....10

**2.4 References:**.....10

**2.5 Insurance Claims against Bidder**.....10

**3. CONTRACT TERMS AND CONDITIONS**.....11

**3.1 Term of Contract**.....11

**3.2 Anti-Discrimination**.....11

**3.3 Antitrust**.....11

**3.4 Assignment of Interest**.....12

**3.5 Availability of Funds**.....12

**3.6 Contract Changes / Change Orders**.....12

**3.7 Contractor’s Responsibilities**.....13

**3.8 Ethics in Public Contracting**.....13

**3.9 Examination of Records**.....13

**3.10 Governing Law; Venue; Waiver of Jury Trial**.....14

**3.11 Indemnification and Responsibility for Claims and Liability**.....14

**3.12 Insurance**.....14

**3.13 No Waiver or Estoppel**.....16

**3.14 Partial Invalidity**.....16

**3.15 Payment Clauses Required in All Contracts**.....16

**3.16 Payment**.....17

**3.17 Price Firm Period**.....18

**3.18 Annual Economic Price Adjustment**.....18

**3.19 Taxes**.....18

**3.20 Termination of Contract**.....18

**3.21 Virginia Freedom of Information Act**.....19

**IFB 23-067**

**Commercial Diver Services to Clean Potomac River Offshore, and Onshore Intakes**

**3.22 Faith-Based Organizations.....19**  
**3.23 No Employment of Unauthorized Aliens .....19**  
**3.24 Severability .....20**  
**3.25 Licensure.....20**  
**3.26 Authorization to Transact Business in Virginia.....20**  
**3.27 Right of Audit.....20**  
**3.28 Drug-free Workplace to be Maintained by Contractor .....20**  
**3.29 Non-Discrimination by CONTRACTOR .....21**  
**3.30 Counterparts .....22**  
**3.31 Survival of Terms.....22**  
**3.32 Non-Waiver .....22**  
**3.33 Dispute Resolution Process .....22**  
**4. SPECIAL TERMS AND CONDITIONS.....23**  
**4.1 Contractor's Compliance and Safety Program .....23**  
**4.2 Contractor's Responsibilities .....23**  
**4.3 Delays.....24**  
**4.4 Force Majeure .....24**  
**4.5 Inspection of Job Site.....25**  
**4.6 Priority Customer .....25**  
**4.7 Site Safety and Access .....25**  
**4.8 Superintendence by Contractor .....26**  
**4.9 Time Is Of The Essence .....26**

<b>Attachment 1</b>	<b>Bid Submission Form</b>
<b>Attachment 2</b>	<b>References</b>
<b>Attachment 3</b>	<b>Daily Diver Inspection Form</b>
<b>Attachment 4</b>	<b>Mustang Load Chart</b>

**IFB 23-067**  
**Commercial Diver Services to Clean Potomac River Offshore, and Onshore Intakes**

**SECTION 1**

**SUMMARY INFORMATION AND SUBMISSION OF BIDS**

**1.0 Introduction**

The Fairfax County Water Authority, doing business as Fairfax Water (FW) was created under the Virginia Water and Waste Authorities Act pursuant to resolutions adopted by Fairfax County on September 26, 1957. Fairfax Water is managed by a ten-member Board of Directors appointed for three-year terms by the Fairfax County Board of Supervisors.

**1.1 Objective**

The objective of this Invitation for Bid (IFB) and resulting award is to establish an annual contract to an experienced, certified dive crew to clean and inspect FW's Potomac River Offshore, and Onshore Intakes as outlined in Section 2.0, Specifications and Related Requirements. In order to be deemed responsive to this IFB, bidders shall submit prices for all items listed on the Bid Submission Form, Attachment 1.

**1.2 Cancellation**

FW may cancel this solicitation at any time and for any reason prior to contract award.

**1.3 Familiarity with Specifications**

Each Bidder is responsible for thoroughly examining this solicitation in its entirety. Any questions or comments regarding the proper meaning or intent of any aspect of this solicitation, shall be submitted in writing to the Procurement Contact prior to the deadline identified on the cover sheet of this solicitation.

The submission of a Bid by the Bidder in response to this solicitation shall be deemed to constitute a representation on the part of such Bidder that it has thoroughly examined this solicitation and has submitted any and all questions and comments they may have regarding the meaning or interpretation of this solicitation to Fairfax Water in the manner prescribed herein.

**1.4 Optional Pre-Bid Site Visit**

- A. An optional, **non-mandatory**, site visit will be held at 100 Seneca Road, Great Falls, Virginia, 22066 at 8:30 a.m., October 17, 2023.
- B. Contractors attending the site visit must notify the Procurement Contact via e-mail prior to 12:00 p.m., October 16, 2023. A visitor's list of those attending will be provided to Fairfax Water staff in advance. Anyone not responding by the deadline will not be placed on the visitor's list. Anyone who is not on the list shall not be admitted.
- C. Plans for the offshore intake will be available for viewing during the site visit. No copies, or photos of the intake plans are permitted.

## IFB 23-067

### Commercial Diver Services to Clean Potomac River Offshore, and Onshore Intakes

- D. Contractors must meet Fairfax Water staff promptly, by 10:00 a.m., October 18, 2023 to gain entry to the site.
- E. Questions will not be permitted during the site visit. Questions and comments regarding the site visit must be submitted in writing to the Procurement Contact prior to 12:00 p.m. October 20, 2023 deadline.

#### 1.5 Questions and Communications

All contact between prospective Bidders and FW with respect to this solicitation will be formally held at scheduled meetings or in writing through the Issuing Office. Questions and comments regarding the meaning or interpretation of any aspect of this solicitation must be submitted in writing to the Procurement Contact identified on the cover page to this solicitation and must be received on or before the deadline for submitting questions. Only written questions will be accepted. Questions and/or comments which are submitted after the deadline set forth on the cover page to this solicitation will not be answered.

FW will respond to all timely questions and comments that are properly submitted and are deemed to address a matter that is relevant and substantive in nature within a reasonable period of time, in the form of a written Addendum that will be transmitted to all prospective Bidders at the addresses furnished to FW for such purpose. Oral communications between FW and any Bidder regarding the interpretation or meaning of any aspect of this IFB are not authorized and may not be relied upon for any purpose.

#### 1.6 Definitions

- A. **Award** – means the decision by FW to execute a contract after all necessary approvals have been obtained.
- B. **Bid** – means the response by a Bidder to an Invitation for Bids issued by a procurement agency to obtain goods or services. For purposes of this solicitation the term **Bid** has the same meaning as **Quote**.
- C. **Bidder** – for purposes of this solicitation, means any person submitting a response to this Request for Quote.
- D. **Contract** – means the formal agreement as a result of this solicitation.
- E. **Contract Completion** – means the point in time when FW Project Manager confirms in writing that the contract has been completed as contracted for and the Contractor is released from any further obligations. All remaining payments due the Contractor shall be approved for payment at this time.
- F. **Contractor** – means the successful Bidder receiving a contract as a result of this solicitation.
- G. **Default** – means that the Contractor has failed to fulfill its contractual obligations properly and on time.
- H. **FW** – means Fairfax Water. The terms Owner and FW have the same meaning.
- I. **Invitation to Bid (IFB) and Request for Quote (IFB)** – for purposes of this solicitation, these terms have the same meaning and refer to this solicitation.
- J. **Notice** – The term “Notice” or the requirement to notify means a written communication delivered in person, by facsimile, or by certified or registered mail to the individual or firm, or to an officer of the Contractor for whom it is intended.

**IFB 23-067**

**Commercial Diver Services to Clean Potomac River Offshore, and Onshore Intakes**

- K. **Owner** – Fairfax County Water Authority.
- L. **Project** – The term “Project” means the same as the phrase “the Work.”
- M. **Site Manager** – means FW employee assigned to this project for purposes of oversight of the project. The Project Manager is responsible for all aspects of the contract (excluding contract modifications) after contract award, including but not limited to approving design changes, and authorizing payment for completed work.
- N. **Specifications** – The term “Specifications” describes the physical or functional characteristics or the nature of a good, service or construction item required. It may include a description of any requirement for inspecting, testing, or preparing a good, services or construction item for delivery.
- O. **Work** – The word “Work” shall include all material, labor equipment and tools, appliances, machinery, transportation, and appurtenances necessary to perform and complete the Contract, and any such additional items not specifically indicated or described which can be reasonably inferred as belonging to the item described or indicated or as required by industry practice, custom or usage to complete the project as proposed by the Bidder and accepted by FW.

**1.7 Instructions for Submitting Bids**

The deadline for submitting bids and the location for opening bids is shown on the cover sheet. Bids will be opened immediately following the deadline for submitting bids. Bids will be opened in accordance with the provisions of the Virginia Public Procurement Act.

**All bids must be submitted in a sealed package(s), no other form of submission will be accepted (i.e., E-mail, Facsimile, etc.). Bid packages must be identified on the outside as follows:**

From: \_\_\_\_\_

Name of Bidder		Due Date
Street	S A M P L E	IFB No.
City, State, Zip Code		IFB Title

Attn: Laurie Hankins

**1.8 Bid Submission Package**

- A. Attachment 1- Bid Submission Form, must be completed and signed by an agent fully authorized to bind the individual, or organization submitting the offer, to the terms, conditions, and specifications contained herein as well as any addenda to this solicitation.
- B. Attachment 2- References, a minimum of three (3) references shall be provided where bidder has performed similar services within the last 3-years.
- C. OSHA Form No. 300 and a list of all citations which have become final or which were the subject of a settlement agreement, in the preceding three year period for: (1) willful

## IFB 23-067

### Commercial Diver Services to Clean Potomac River Offshore, and Onshore Intakes

violations, violations for failure to abate, or repeated violations, for which the bidder was cited by (a) the United States Occupational Safety and Health Administration; (b) the Virginia Occupational Safety and Health Administration; or (c) the occupational safety and health plan of any other state; and (2) serious construction safety violations for which the bidder was cited by the United States Occupational Safety and Health Administration or the Virginia Occupational Safety and Health Administration following a report or notification to the bidder, his agent or employee of such hazard of potential violation by a Fairfax County Inspector or by a FW Inspector. The Bidder may include a statement of any facts surrounding any citation or violation, which may be relevant, as well as a description of any safety measures or safety training programs instituted since the issuance of any citation or the occurrence of any violation. The Bidder shall certify by sworn affidavit that said list is complete.

- D. Any insurance claims as specified in Section 2, Paragraph 2.5.
- E. The Bidder shall provide a list of each diver's previous experience, including training and copies of applicable certifications with their bid.

#### 1.9 Cancellation

FW may cancel this solicitation at any time and for any reason prior to contract award.

#### 1.10 Proprietary Information

- A. Except as provided herein or as otherwise set forth in §2.2-4342 of the Virginia Public Procurement Act (Va. Code Ann. §2.2-4300 *et seq.*, the "Act"), all proceedings, records, contracts and other public records relating to procurement transactions shall be open to inspection in accordance with the Virginia Freedom of Information Act (Va. Code Ann. §2.2-3700 *et seq.*, the "Virginia FOIA").
- B. A Bidder, Offeror or Contractor will have the right to identify data or other materials submitted in connection with this procurement as trade secrets or proprietary information, which shall not be subject to inspection pursuant to either §2.2-4342 of the Act or the Virginia FOIA, by submitting to FW prior to or at the time of submission of its proposal or bid a separate, written notice on its letterhead stationery setting forth the following: (i) a statement indicating that the Bidder, Offeror, or Contractor wishes to invoke the protections of this section; (ii) an identification of the data or other materials for which protection is sought; and (iii) a statement with regard to why protection is necessary.

#### 1.11 Exceptions/Additions

Exceptions or additions to Section 2 SPECIFICATIONS in its entirety, Section 3 CONTRACT TERMS AND CONDITIONS, and Section 4 SPECIAL TERMS AND CONDITIONS in its entirety will not be permitted. Any questions or concerns regarding any part of this IFB shall be submitted in accordance with Section 1.5 of this solicitation. Bids containing any exceptions to Section 2 through Section 4 or submitting additional contract terms and conditions shall be deemed non-responsive and rejected. Exceptions or additions proposed after quote submission by the successful bidder will not be accepted.

## **IFB 23-067**

### **Commercial Diver Services to Clean Potomac River Offshore, and Onshore Intakes**

#### **1.12 Addenda to the IFB**

- A. FW reserves the right to amend this solicitation at any time prior to the deadline for submitting Bids. If it becomes necessary to revise any part of this IFB, notice of the revision will be given in the form of an Addendum that will be provided to all prospective Bidders who are on record with FW as having received this solicitation. If, in the opinion of FW, the deadline for the submission of bids does not provide sufficient time for consideration of any Addendum, then such deadline may be extended at the discretion of FW.
  
- B. Each Bidder shall be responsible for contacting the Purchasing Contact identified on the cover page to this solicitation prior to submission of a quote hereunder in order to determine whether any Addenda have been issued in connection with this procurement. Notwithstanding any provision to the contrary, the failure of any Bidder to receive any Addenda shall neither constitute grounds for withdrawal of its quote, nor relieve such Bidder from any responsibility for incorporating the provisions of any Addenda in its proposal.

#### **1.13 Receipt of Addenda**

Acknowledge receipt of each addendum by signing and submitting it by the quote deadline.

#### **1.14 Late Bids**

Bids or unsolicited amendments to bids arriving after the bid submission deadline will not be considered.

#### **1.15 Contract Award**

The contract will be awarded for each item to the lowest responsive and responsible Bidder(s). FW reserves the right to award contracts in the aggregate or separately whichever is in the best interest of FW. Whenever the lowest responsive and responsible bidder is a resident of a state other than Virginia and such state under its laws allows a resident contractor of that state a percentage preference, a like preference shall be allowed to the lowest responsive and responsible bidder who is a resident of Virginia and is the next lowest bidder. If the lowest bidder is a resident contractor of a state with an absolute preference, the bid preference shall not be considered.

#### **1.16 Term of Contract and Contract Renewal**

- A. The Contract(s) awarded as a result of this solicitation will be effective for one-year beginning on the date of contract award. FW reserves the unilateral option to renew all contracts annually thereafter for up to four (4) additional one-year periods, subject to the terms and conditions specified herein.
  
- B. Notification of renewal shall be by the issuance of a renewal letter/contract amendment. Failure to renew by the expiration date of the then current contract year will not automatically cancel the contract. FW may retroactively renew the contract at any time

**IFB 23-067**

**Commercial Diver Services to Clean Potomac River Offshore, and Onshore Intakes**

prior to the last day of the following contract year providing that FW has not formally canceled the contract(s).

**2.0 BID SPECIFICATIONS AND RELATED REQUIREMENTS**

**2.1 Contract Requirements**

- A. It is the intent of FW to establish a contract for underwater diving services to be performed at the Potomac River for both the offshore, and onshore intake facilities. The work involves removing a combination of silt, sand, debris, sticks and logs from both intakes in accordance with the following specifications. Time is of the essence for this project; therefore, ***the successful Bidder shall be required to mobilize and begin work within two days of FW issuing a Purchase Order.*** Our target start date, although not guaranteed, is December 04, 2023. The time to complete the project once work has begun is ~ **14 consecutive calendar days**. The successful contractor shall be required to complete the project within this allotted number of days, without exception, except as described in Paragraph 2.1.B. Workdays and hours shall be defined as seven days per week between 5:00 a.m. and 10:00 p.m. **The contractor must actively remove (pump) sediment at least 8 hours per workday (transportation to and from the job site shall not be included as part of the 8 hours of pumping per day).**
  
- B. **EXCUSABLE DELAYS:** While cleaning the Offshore Intake, if the river flow increases to 15,000 CFS at Point of Rocks, Maryland, (as measured at the USGS River Gauge Station) and the Contractor can no longer safely and effectively remove debris from the Offshore Intake, the Contractor must evacuate the river and suspend cleaning operations. Once the Contractor, with the concurrence of the FW Project Manager, determines that it is safe to resume cleaning operations (< 15,000 CFS), FW staff and the Contractor will inspect the Offshore Intake to determine if additional debris has been deposited into the Intake structure. The daily reports (see Attachment 4) submitted prior to the start of the unsafe conditions shall serve as the guiding documentation of the previously cleaned condition of the Intake. As discussed in Paragraph 2.2.A.1.c, if unsafe conditions will require re-cleaning operations, the Contractor shall be entitled to receive additional compensation.
  
- C. Dive Services shall be defined as furnishing all labor, supervision, supplies, materials, equipment, and insurance necessary to perform the services as outlined within these specifications and in accordance with the latest version of Occupational Safety and Health Administration (OSHA) Standard 29 CFR – Commercial Diving Operations, and all federal, state and local codes, laws and statutes. Neither a NPDES permit nor debris removal permit are required for this project.
  
- D. All dive personnel assigned to the project shall possess a current and valid Association of Diving Contractors International, Inc. (ADCI) Commercial Diver Certification Card and have been formally trained in commercial diving, either through a public or private accredited diving school. Other industry standard certifications/licenses may be considered in lieu of the ADCI Certification Card.

**IFB 23-067**

**Commercial Diver Services to Clean Potomac River Offshore, and Onshore Intakes**

- E. The successful bidder(s) shall furnish a crew sufficient in number and size to complete the project in the designated time. The contractor shall furnish at a minimum at least one 3-man crew to perform the work. Under no circumstance shall the crew size be less than three members, at least one of whom shall be a diver approved by FW's Project Manager.
- F. Mechanical dredging is not permissible for any portion of this project.
- G. Hydraulic Lifting: Hydraulic lifting of silt is allowed. Offshore Intake water depth is typically 4-5 feet deep.
- H. Historical Potomac River Flow Rates: The following web page will provide flow data; Point of Rocks is the closest upstream station:

[http://waterdata.usgs.gov/md/nwis/current/?type=flow&group\\_key=basin\\_cd](http://waterdata.usgs.gov/md/nwis/current/?type=flow&group_key=basin_cd)

**2.2 Scope of Work:**

- A. Potomac River Offshore Intake is located approximately 780 feet from the shoreline.
  - 1. CURRENT SEDIMENT LEVEL MEASUREMENTS AND THE CONTRACTOR BIDDING METHODOLOGY AND PAYMENT FOR EXTRA WORK:
    - a. Cleanings shall be annually in the fall/early winter of each year. The Owner will contact the contractor to initiate the cleaning. Before each cleaning, FW will take measurements of the intake as described herein.
    - b. FW can only measure buildup from above by boat. FW cannot measure the buildup, if any, in the vertical portion of the Intake as it has a concrete cover. The vertical portion may be accessed by a diver through an underwater side access door. The access grate hatch is hinged on one side and is made of 3.5 x 0.25-inch HWE grating. Grate opening is approximately 4 inches on center. A pump has been successfully used in the past to remove debris, sediment, sticks, and rocks.
    - c. On October 11, 2023 FW staff measured the sediment level in the Offshore Intake and found the following: NW quadrant 4.0 feet deep, NE quadrant 0.0 feet deep, SW quadrant 3.0 feet deep, SE quadrant 3.0 feet deep. Seven feet of depth is when the intake quadrant is full. The total volume of the ring portion of the intake is approximately 14,300 cubic feet. The total volume of the vertical portion of the intake is approximately 1,060 cubic feet.
    - d. If during the cleaning operation the Contractor is forced to leave the river due to high river flows (> 15,000 cfs), the Contractor and FW staff will take new measurements of the sediment levels in the Offshore Intake once they can resume cleaning operations. This will determine if additional debris were deposited in the intake during the high flow event. The Item #1 Base Lump Sum Bid Price will be adjusted up, if

**IFB 23-067**

**Commercial Diver Services to Clean Potomac River Offshore, and Onshore Intakes**

necessary, based on the average percentage change of depth of debris in the Offshore Intake, according to the following formula:

$$\frac{\text{NW Quad Depth} + \text{NE Quad Depth} + \text{SW Quad Depth} + \text{SE Quad Depth}}{4} = \text{Average Depth (Feet)}$$

**For example:** Existing depths when suspending cleaning operations:

$$\frac{5.6 + 5.6 + 6.6 + 2.2}{4} = \text{5.0 Feet Average Depth}$$

New depths once cleaning can resume: are NW = 6.0, NE = 6.0, SW = 7.0, SE = 3.0, then

$$\frac{6.0 + 6.0 + 7.0 + 3.0}{4} = \text{5.5 Feet New Average Depth}$$

Therefore, increase equals:

$$\frac{5.5 - 5.0}{5.0} \times 100 = \text{10.0\% Increase to Line Item \#1}$$

2. Offshore Intake Work Tasks

- a. Clear the west (upstream) wall 1 foot down from top of outer structure (jersey barrier) or to bedrock, whichever is achieved first. Taper out five feet to existing grade.
- b. Clear the entire inside down to bottom of 90-degree pipe bend (elevation 157.0 feet) of debris and sand (under horizontal and inside vertical grate). The bottom elevation of the ring portion is 169.0 feet. The top elevation of the Intake is 176.5 feet. Normal water elevation is 180.8 feet but will vary above or below this measurement depending upon the then current river flow.
- c. All silt or debris shall be pumped or moved from the Offshore Intake structure at a minimum of 20 feet downstream of the Offshore Intake and deposited back into the Potomac River thereby allowing the material to continue to flow downstream and away from the structure.
- d. Contractor shall provide the FW Project Manager or his designee, with a written daily diver inspection report of work performed. The report shall clearly state the volume of debris removed, shading in area where debris was removed on attached drawing (Intake #2 Plan), number of hours worked and the percentage of the total Offshore Intake cleaned to date, see Attachment 3.

**IFB 23-067**

**Commercial Diver Services to Clean Potomac River Offshore, and Onshore Intakes**

- e. Report the amount of solids build-up in the horizontal pipe, without penetrating or entering the pipe. Bidders may assume FW requires only one measurement at the beginning of the horizontal pipe at the 90-degree bend and a verbal assessment of whatever can be seen down the pipe.
- f. After all cleaning is completed, divers shall remove the offshore sample pump discharge screen, clean it and reinstall after Fairfax Water personnel blow the sample lines clear. The FW Project Manager, or his designee, will inspect site to ensure completeness and final acceptance.

**B. Potomac River Onshore Intake Work Tasks:**

- a. Clear all debris in front of vertical bar grates down to river bottom and out past the wooden float booms to approximately 30 feet in distance. Fairfax Water will be responsible for disposing of material.
- b. Clear all debris upstream and downstream of the structure up to and including the boat ramp.
- c. Locate and reset jersey barriers and trash boom back to normal distance (to be set by FW) from Onshore Intake. Jersey barriers are submerged and may need to be floated (repositioned) so that the boom can be attached to the Jersey barrier. If river level allows, the Jersey barriers can be floated with contractor supplied float bags. If river is very low and float bags will not work, then Fairfax Water will supply a crane. The floating boom is currently located near the intake bar screens. It needs to be pulled out and anchored to the Jersey barriers about 30 feet from the bar screens.
- d. After cleaning is completed, divers shall remove the onshore sample pump discharge screen, clean it and reinstall after Fairfax Water personnel blow the sample lines clear. The FW Project Manager, or his designee, will inspect site to ensure completeness and final acceptance.

**C. Fairfax Water Supplied Material/Equipment:**

- 1. Boom forklift – Mustang Model 1155, MAX CAPACITY 3,500 LB. (See Attachment 4, Mustang Load Chart).
- 2. Power and Water Service Line Availability: Power is available at the Onshore Intake Structure; 480 volts, 3phase, 60 amps. No water service lines are available.
- 3. 8' wide x 24' long barge boat work platform and boat launch that is located at the work site. FW will provide launch/recovery assistance to contractor. If river conditions allow, and with the concurrence of the FW Project Manager, the boat may be tied off to the Onshore Intake so that it does not have to be fully removed at the end of each workday. FW will not provide an operator for the boat. The boat work platform shall only be used to transport personnel and lightweight diving equipment.

## **IFB 23-067**

### **Commercial Diver Services to Clean Potomac River Offshore, and Onshore Intakes**

The boat work platform shall not be used to carry or transport other equipment such as pumps. NOTE: If contractor uses boat platform, FW will not be held responsible for any down time resulting from malfunctions of boat or motor.

#### **2.3 Crew Size:**

- A. The Contractor shall furnish, at a minimum, a 3-member dive crew comprised of a Dive Supervisor, Diver, and Standby Diver. Under no circumstance shall the crew size be less than three members.
- B. The Contactor shall provide a list of each employee's previous experience, including training and certifications with their bid.
- C. Prior to beginning work, the Contractor shall submit a list of crew assignments and designate one employee to function as the point-of-contact for all matters regarding service throughout the duration of the contract.

#### **2.4 References:**

Each Bidder must submit with its Bid, three references (See Attachment 2 – References). References shall be from customers of similar size and scope of operations as FW, to whom the Bidder has supplied the same services within the past 12 months. References must be able to attest without reservation to the fact that the Bidder provided the contracted goods/services without a significant problem of any kind, and at any time during the contract period.

#### **2.5 Insurance Claims against Bidder**

In addition to the mandatory insurance requirements listed in Subsection 3.12 Insurance, and at the request of FW, the apparent low bidder shall submit a list of all insurance claims made against it within the past 12 months. Failure to include this information within ten calendar days of request by FW may result in rejection of your bid.

**Commercial Diver Services to Clean Potomac River Offshore, and Onshore Intakes**

**3. CONTRACT TERMS AND CONDITIONS**

**3.1 Term of Contract**

The term of the contract shall be for 12 months from date of award with possible renewals as described in section 1.16.

**3.2 Anti-Discrimination**

By submitting their bids, Bidders certify to FW that they will conform to the provisions of the Federal Civil Rights Act of 1964, as amended, as well as the Virginia Fair Employment Contracting Act of 1975, as amended, where applicable, the Virginians With Disabilities Act, the Americans With Disabilities Act and §11-51 of the Virginia Public Procurement Act.

A. During the performance of the contract, the Contractor agrees as follows:

1. The Contractor will not discriminate against any employee or applicant for employment because of race, religion, color, sex, national origin, or disabilities, except where religion, sex or national origin is a bona fide occupational qualification reasonably necessary to the normal operation of the Contractor. The Contractor agrees to post in conspicuous places, available to employees and applicants for employment, notices setting forth the provisions of this nondiscrimination clause.
2. The Contractor, in all solicitations or advertisements for employees placed by or on behalf of the Contractor, will state that such Contractor is an equal opportunity employer.
3. Notices, advertisements and solicitations placed in accordance with federal law, rule or regulation shall be deemed sufficient for the purpose of meeting these requirements.

B. The Contractor will include the provisions above in every subcontract or purchase order so that the provisions will be binding upon each subcontractor or vendor.

C. Fairfax Water does not discriminate against faith-based organizations on the basis of the organization's religious character, or impose conditions that (a) restrict the religious character of the faith-based organization, except as provided by law, or (b) impair, diminish, or discourage the exercise of religious freedom by the recipients of such goods, services, or disbursements.

**3.3 Antitrust**

By entering into a contract, the Contractor conveys, sells, assigns, and transfers to FW all rights, title and interest in and to all causes of action it may now have or hereafter acquire under the antitrust laws of the United States and the Commonwealth of Virginia, relating to the particular goods or services purchased or acquired by FW.

**Commercial Diver Services to Clean Potomac River Offshore, and Onshore Intakes**

**3.4 Assignment of Interest**

The Contractor shall not assign any interest in any resulting Contract and shall not transfer any interest in the same without prior written consent of FW, which FW shall be under no obligation to grant.

**3.5 Availability of Funds**

It is understood and agreed between the parties herein that FW shall be bound hereunder only to the extent of the funds available or which may hereafter become available for the purpose of this agreement.

**3.6 Contract Changes / Change Orders**

A. No verbal agreement or conversation with any officer, agent or employee of FW either before or after the execution of any Contract resulting from this solicitation or follow-on negotiations, shall affect or modify any of the terms, conditions, specifications, or obligations contained in the solicitation, or resulting Contract. No alterations to the terms and conditions of the Contract shall be valid or binding upon FW unless made in writing and signed by the purchasing contact identified on the cover page. Contract changes shall be in writing and shall be on official FW Purchasing Department letterhead. In any event and in all circumstances, the Contractor shall be solely liable and responsible for any Contract changes, deviations, etc., made without first receiving written authorization to deviate from the Contract by the FW Project Manager.

B. Changes can be made to the contract in any of the following ways:

1. The parties may agree in writing to modify the scope of the contract. An increase or decrease in the price of the contract resulting from such modification shall be agreed to by the parties as a part of their written agreement to modify the scope of the contract.
2. FW may order changes within the general scope of the contract at any time by Notice to the Contractor. Changes within the scope of the contract include, but are not limited to, things such as services to be performed, the method of packing or shipment, and the place of delivery or installation. The Contractor shall comply with the notice upon receipt. The Contractor shall be compensated for any additional costs incurred as the result of such order and shall give FW a credit for any savings. Said compensation shall be determined by one of the following methods:
  - a. By mutual agreement between the parties in writing; or
  - b. By agreeing upon a unit price or using a unit price set forth in the contract, if the work to be done can be expressed in units, and the Contractor accounts for the number of units of work performed, subject to FW's right to audit the Contractor's records and/or to determine the correct number of units independently; or
  - c. By ordering the Contractor to proceed with the work and keep a record of all costs incurred and savings realized. A markup for overhead and profit may be allowed

## **IFB 23-067**

### **Commercial Diver Services to Clean Potomac River Offshore, and Onshore Intakes**

if provided by the contract. The same markup shall be used for determining a decrease in price as the result of savings realized. The Contractor shall present FW with all vouchers and records of expenses incurred and savings realized. FW shall have the right to audit the records of the Contractor, as it deems necessary to determine costs or savings. Any claim for an adjustment in price under this provision must be asserted by Notice to the Purchasing Department. Neither the existence of a claim nor a dispute resolution process, litigation or any other provision of this contract shall excuse the Contractor from promptly complying with the changes ordered by FW or with the performance of the contract generally.

#### **3.7 Contractor's Responsibilities**

- A. The Contractor shall be responsible for all products and/or services as required by this IFB. The use of subcontractors is prohibited unless:
  - 1. A request to include a subcontractor is included in the bid and,
  - 2. The Bidder receives written approval to use a subcontractor prior to, or as part of the formal contract between the parties.
- B. Even when properly authorized by FW, the use of a subcontractor does not relieve the Contractor of liability under the contract.
- C. The Contractor, at its sole expense, shall be responsible for damage to FW and non-FW property as a result of its failure, or its subcontractor's failure to protect such facilities and utilities.
- D. The Contractor, at its sole expense, shall immediately repair or replace FW property damaged by (or caused by) the Contractor or its Subcontractor(s). Replacements will be of equal or better quality than the property damaged property, and all such work must be approved by FW Project Manager.

#### **3.8 Ethics in Public Contracting**

Contractor hereby certifies that it has familiarized itself with Article 4 of Title 11 of the Virginia Public Procurement Act, Section 11-72 through 80, Virginia Code Annotated, and that all amounts received by it, pursuant to a contract resulting from this solicitation, are proper and in accordance therewith.

#### **3.9 Examination of Records**

Bidder agrees that in any resulting contract, either FW or its duly authorized representative shall have access to and the right to examine and copy any directly pertinent books, documents, papers, and records of the Contractor involving transactions related to any resulting contract. This obligation shall expire five years after the final payment for the final service performed as a result of any and all contract(s) awarded pursuant to this solicitation, or until audited by FW, whichever is sooner. Contractor will provide reasonable access to any and all necessary documents and upon demand provide copies of documents if so

**IFB 23-067**

**Commercial Diver Services to Clean Potomac River Offshore, and Onshore Intakes**

required by FW or its representative(s). FW will reimburse the Contractor for any reasonable expenses it incurs as a result of such a request.

**3.10 Governing Law; Venue; Waiver of Jury Trial**

Notwithstanding any provision to the contrary, this solicitation and any resulting contract shall be governed in all respects by the laws of the Commonwealth of Virginia. Any dispute arising hereunder which is not otherwise resolved by the parties shall be resolved by a court of competent jurisdiction in the Commonwealth of Virginia. The Contractor and FW hereby waive any right such party may have to a trial by jury in connection with any such litigation.

**3.11 Indemnification and Responsibility for Claims and Liability**

With respect to any contract that results from this solicitation, Bidder is bound by the following:

- A. The Contractor shall indemnify, save harmless and defend FW, or any employee of FW, against liability for any suits, actions, or claims of any character whatsoever arising from or relating to the performance of the Contractor or its subcontractors under this contract.
- B. FW has no obligation to provide legal counsel or defense, or pay attorney's fees to the Contractor or its subcontractors in the event that a suit or action of any character is brought by any person not party to the contract, against the Contractor or its subcontractors as a result of or relating to the Contractor's obligations under this contract.
- C. FW has no obligation for the payment of any judgments or the settlement of any claims against the Contractor or its subcontractors as a result of or relating to the Contractor's obligations under this contract.
- D. The Contractor shall immediately notify FW of any claim or suit made or filed against the Contractor or its subcontractors regarding any matter resulting from or related to the Contractor's obligations under the contract. If such a claim or suit is brought, the Contractor will cooperate, assist, and consult with FW in the defense or investigation of any suit or action made or filed against FW as a result of or relating to the Contractor's performance under this contract.
- E. The Contractor shall pay all royalties and license fees necessary for performance of the contract. The Contractor shall defend all suits or claims for infringement of any patent rights or other proprietary rights arising from or related to performance of the resulting contract and shall save FW harmless from any loss, including Attorneys' fees arising out of any such claim.

**3.12 Insurance**

- A. In addition to the mandatory insurance requirements listed in this Section and, at the request of FW, any Bidder may be required to provide a list of all insurance claims made against it within the past 36 months. FW reserves the right to reject any bid if in FW's

**IFB 23-067**

**Commercial Diver Services to Clean Potomac River Offshore, and Onshore Intakes**

opinion the amount or number of claims is deemed to be excessive. A Bidder's failure to comply with this requirement may result in rejection of its bid. If no claims have been made, then the Bidder shall so state in its bid. Fairfax Water may require such information from the Contractor as it deems necessary to assess the Contractor's financial ability to pay any deductibles with respect to the insurance policies required hereunder.

- B. Before commencing the work, the Contractor shall procure and maintain at its own expense, minimum insurance in forms and with insurance companies acceptable to FW to cover loss or liability arising out of the Work. All insurance policies must be underwritten by insurers authorized to conduct business within the Commonwealth of Virginia and must have a Best's rating of at least A- and a financial size of class VIII or better in the latest edition of Best's Insurance Reports.
- C. The Contractor shall immediately notify FW of any claim or suit made or filed against the Contractor or its subcontractors regarding any matter resulting from or related to the Contractor's obligations under the contract. If such a claim or suit is brought, the Contractor will cooperate, assist, and consult with FW in the defense or investigation of any suit or action made or filed against FW as a result of or relating to the Contractor's performance under this contract.
- D. With the exception of Workers' Compensation and Employers' Liability Insurance, all additional insurance policies specified herein shall name FW as an additional insured with regard to work performed under any subsequent Contract
- E. The Contractor will provide FW with copies of certificates of insurance coverage and proof of payment of all premiums. Each certificate of insurance must include: (a) an endorsement from the insurer that certifies that the Contractor maintains the referenced policy in full force and effect; (b) where applicable, a statement indicating that FW is included as an additional insured; and (c) a provision requiring that not less than 30 days written notice will be given to FW before any policy or coverage is canceled or modified in any material respect. Without limiting the requirements set forth above, the insurance coverages will include a minimum of:
  - 1. Workers' Compensation and Employers' Liability Insurance: Statutory requirements and benefits as required by the Commonwealth of Virginia; and
  - 2. Required Commercial General Liability Insurance: This insurance must be written on an "occurrence" basis and shall be endorsed to include FW as an additional insured and shall provide at a minimum the following:

◆ General Aggregate Limit (Other than Products-Completed Operations)	\$1,000,000
◆ Products-Completed Operations Aggregate Limit	\$ 500,000
◆ Personal & Advertising Injury Limit	\$ 500,000
◆ Each Occurrence Limit	\$ 500,000
- F. Business Automobile Liability Insurance: This insurance coverage must extend to any motor vehicles or other motorized equipment regardless of whether it is owned, hired, or

## **IFB 23-067**

### **Commercial Diver Services to Clean Potomac River Offshore, and Onshore Intakes**

non-owned and must cover Bodily Injury and Property Damage with a combined single limit of at least \$1,000,000 each accident. This insurance must be written in comprehensive form and must protect the Contractor and FW against claims for injuries to members of the public and/or damage to the property of others arising from the Contractor's use of motor vehicles or other equipment and must cover both on-site and off-site operations.

- G. Nothing contained herein will be deemed to operate as a waiver of FW's sovereign immunity under the law.

#### **3.13 No Waiver or Estoppel**

Neither the inspection by FW nor any of its employees, nor any payment of money, nor payment for, nor acceptance of any Commodity by FW, nor any extension of time shall operate as a waiver of any provision of this Contract, or of any power herein reserved to the Owner or of any right to damage herein provided. No waiver of any breach of this Contract shall be held to be a waiver of any other subsequent breach. All remedies provided in this Contract to FW shall be construed as cumulative and shall be in addition to each and every other remedy herein provided. Neither FW, nor any officer, employee, or authorized representative of FW, will be bound, precluded, or estopped by any action, determination, decision, acceptance, return, certificate, or payment made or given under or in connection with the Contract by any officer, employee or authorized representative of the Owner, at any time either before or after final completion and acceptance of the Work and payment therefore from: (a) showing the true and correct classification, amount, quality, or character of the Commodities delivered, or that any determination, decision, acceptance, return certificate or payment was incorrect or was improperly made in any respect, or that the Commodities or any part thereof do not in fact conform to the requirements of the Contract; (b) demanding and recovering from the Contractor any overpayment made to the Contractor or such damages as FW may sustain by reason of the Contractor's failure to comply with the requirements of the Contract; or (c) both of the foregoing clauses (a) and (b).

#### **3.14 Partial Invalidity**

Neither any payment for, nor acceptance of, the whole or any part of the services by FW, nor any extension of time, shall operate as a waiver of any provision of any Contract resulting from this IFB, nor of any power herein reserved to FW, or any right to damages herein provided, nor shall any waiver of any breach of any Contract be held to be a waiver of any other or subsequent breach. Failure of FW to require compliance with any term or condition of any Contract shall not be deemed a waiver of such term or condition or a waiver of the subsequent enforcement thereof.

#### **3.15 Payment Clauses Required in All Contracts**

Section § 2.2-4352 of the Virginia Public Procurement Act requires the following:

- A. That any contract awarded by FW include the following clauses:

**IFB 23-067**

**Commercial Diver Services to Clean Potomac River Offshore, and Onshore Intakes**

1. The Contractor shall take one of the two following actions within seven days after receipt of amounts paid to the contractor by FW for work performed by any subcontractor(s) under the contract:
    - a. The Contractor shall pay its subcontractor(s) for the proportionate share of the total payment received from FW attributable to the work performed by the subcontractor under that contract; or
    - b. Notify FW and any subcontractor(s), in writing, of his intention to withhold all or a part of the subcontractor's payment with the reason for nonpayment.
  2. Bidders shall include in their offer submissions either: (i) if an individual contractor, their social security numbers; and (ii) proprietorships, partnerships, and corporations to provide their federal employer identification numbers.
  3. The contractor shall pay interest to the subcontractor(s) on all amounts owed by the Contractor that remain unpaid after seven days following receipt by the Contractor of payment from FW for work performed by the subcontractor under the contract, except for amounts withheld as allowed in subdivision 1.
  4. Unless otherwise provided under the terms of this contract, interest shall accrue at the rate of one percent per month.
- B. The contractor shall include in each of its subcontracts a provision requiring each subcontractor to include or otherwise be subject to the same payment and interest requirements with respect to each lower-tier subcontractor.
- C. A contractor's obligation to pay an interest charge to a subcontractor pursuant to the payment clause in this section shall not be construed to be an obligation of FW. A contract modification shall not be made for the purpose of providing reimbursement for the interest charge. A cost reimbursement claim shall not include any amount for reimbursement for the interest charge.

**3.16 Payment**

- A. Invoices: All invoices are to be sent directly to FW Accounts Payable department by mail, fax, or e-mail. Invoices shall include the FW Purchase Order / Contract number and the contractor's FEIN. Invoices are not to be sent to the contract Project Manager, or other departmental reps. Failure to comply may result in late payments for which FW will not be liable.
- B. Terms: All payments will be Net 30 from the date of receipt of a valid invoice at FW Finance Department. Payment terms requiring payment in less than 30 days will be regarded as requiring payment 30 days after invoice or delivery, whichever occurs last. This shall not affect offers of discounts for payment in less than 30 days, however.
- C. Partial Payments: Requests for partial payments or advanced payments must be submitted as part of the Price Bid along with a justification. FW reserves the right to

## **IFB 23-067**

### **Commercial Diver Services to Clean Potomac River Offshore, and Onshore Intakes**

accept, reject or negotiate requests for partial payments. If the request is rejected, the Bidder must waive the requirement in order to remain in consideration.

- D. Refunds: If the Contractor is declared to be in default, FW will be eligible for a full and immediate refund for all payments made to the Contractor. Partial Payments: Requests for partial payments or advanced payments must be submitted as part of the Price Offer along with a justification. FW reserves the right to accept, reject or negotiate requests for partial payments. If the request is rejected, the Bidder must waive the requirement in order to remain in consideration.
- E. Unreasonable Charges: Under certain emergency procurements and for most time and material purchases, final job costs cannot be accurately determined at the time orders are placed. In such cases, final payment is contingent on a determination of reasonableness with respect to all invoiced charges. Charges that appear to be unreasonable will be researched and challenged, and that portion of the invoice held in abeyance until a settlement can be reached. Upon determining that invoiced charges are not reasonable, FW shall promptly notify the Contractor, in writing, as to those charges that it considers unreasonable and the basis for the determination.

#### **3.17 Price Firm Period**

Bid pricing shall be firm and fixed as originally offered and accepted for the first 12 months of the contract.

#### **3.18 Annual Economic Price Adjustment**

- A. The Contractor may submit a request for contract price increases once annually for each renewal year. Economic increases shall be limited to the increase specified in the Bureau of Labor Statistics for the 12-month period ending 90 days prior to the end of the then current contract year.
- B. For services: Annual rate increases will be based on the Consumer Price Index-U (CPI-U), Washington-Arlington-Alexandria.
- C. Negative BLS index: If the agreed upon index is a negative number the Contractor shall reduce contract rates by the same amount for new contract year.

#### **3.19 Taxes**

FW is exempt from Federal Excise Taxes, Virginia State Sales and Use Taxes, and the District of Columbia Sales Taxes and Transportation Taxes. FW's tax identification number is 54-6025290.

#### **3.20 Termination of Contract**

- A. For Cause. In the event that the Contractor: (1) fails to deliver any Commodity or Service in accordance with the time period established therefore in the Contract; or (2) fails to furnish any Commodity or Service which conforms in all respects to the

## **IFB 23-067**

### **Commercial Diver Services to Clean Potomac River Offshore, and Onshore Intakes**

requirements of the Contract; then FW, without prejudice to any other rights or remedies it may have at law or in equity (including its right to seek damages from the Contractor), shall have the right to terminate the Contract and any outstanding Purchase Orders by issuing a written notice of termination to the Contractor. Such notice of termination shall describe in reasonable detail the grounds for the termination and shall take effect immediately upon receipt by the Contractor.

If, after issuance of a notice of termination under this Section it is determined for any reason that cause for such termination did not exist, then the rights and obligations of the parties shall be the same as if the notice of termination had been delivered under the provisions of subsection B (termination for convenience) hereof; provided, however, that the Contractor in such event shall be deemed to have received seven days prior written notice of such termination. Any compensation due the Contractor pursuant to subsection B shall be offset by the cost to FW of remedying the default by the Contractor. The Contractor shall in no event be entitled to receive any consequential damages or any anticipated profits with respect to Commodities not yet furnished to, and accepted by, FW as of the effective date of any such termination.

- B. For Convenience. FW shall have the right to terminate the Contract and/or any outstanding Purchase Orders issued hereunder at its own convenience for any reason by giving seven business days prior written notice of termination to the Contractor. In such event, the Contractor shall be paid an amount equal to the actual cost of any Commodity delivered to, and accepted by, FW and the actual cost of any equipment, goods or materials ordered by the Contractor hereunder in good faith which could not be canceled, less the salvage value thereof, provided sufficient substantiation is furnished to FW. Any subcontract entered into by the Contractor in connection with the transactions contemplated hereby shall contain a similar termination provision for the benefit of the Contractor and FW. The Contractor shall in no event be entitled to receive anticipated profits on any Commodities not yet furnished to and accepted by FW as of the effective date of any such termination.

#### **3.21 Virginia Freedom of Information Act**

Except as provided herein, all proceedings, records, contracts and other public records relating to procurement transactions shall be open to the inspection of any citizen, any interested person, firm, or corporation, in accordance with the Virginia Freedom of Information Act.

#### **3.22 Faith-Based Organizations**

Non-Discrimination by FW. FW represents and warrants that it does not discriminate against faith-based organizations.

#### **3.23 No Employment of Unauthorized Aliens**

CONTRACTOR hereby covenants and agrees that it does not, and shall not during the term of this MSA, knowingly employ an unauthorized alien (as such term is defined in the federal Immigration Reform and Control Act of 1986).

**Commercial Diver Services to Clean Potomac River Offshore, and Onshore Intakes**

**3.24 Severability**

In the event that any provision shall be adjudged or decreed to be invalid by a court of competent jurisdiction, such ruling shall not invalidate the entire Agreement but shall pertain only to the provision in question and the remaining provisions shall continue to be valid, binding and in full force and effect.

**3.25 Licensure**

To the extent required by the Commonwealth of Virginia (see e.g. 54.1-1100 et seq. of the Code of Virginia) or FW, the Contractor shall be duly licensed to provide the goods and services required to be delivered pursuant to this Contract.

**3.26 Authorization to Transact Business in Virginia**

CONTRACTOR hereby represents and warrants as follows: (a) it is authorized to transact business in the Commonwealth of Virginia as a domestic or foreign business entity if so required by Title 13.1 or Title 50 of the Virginia Code, or as otherwise required by law; and (b) it shall not allow its existence to lapse or its certificate of authority or registration to transact business in Virginia, if so required under Title 13.1 or Title 50 of the Virginia Code, to be revoked or cancelled at any time during the term of this Agreement.

**3.27 Right of Audit**

CONTRACTOR covenants and agrees to retain all books, records and other documents (electronic or otherwise) relating this MSA (the "Project Records") for at least five (5) years after final payment hereunder. Project Records will be deemed to exclude books, records and other documents if and to the extent they are protected by the attorney-client privilege. FW and its authorized agents (the "Auditing Parties") shall have full access to and the right to examine the Project Records upon written request at any time, and from time to time, during the term of this MSA and for a period of five (5) years thereafter. CONTRACTOR hereby covenants and agrees that, within 10 days after it receives written notice from an Auditing Party, it will make the Project Documents available for inspection and copying by such Auditing Party during CONTRACTOR's regular business hours, with copies being provided at a reasonable cost payable by the Auditing Party. Any failure on the part of CONTRACTOR to comply with the provisions of this Section will constitute a breach of the MSA and, regardless of whether such failure occurs during the term of the MSA, or within the five year period commencing on the date of final payment hereunder, will constitute sufficient grounds for debarment of CONTRACTOR. CONTRACTOR hereby agrees that it will pay and be responsible for all costs and expenses (including court costs and attorneys' fees) incurred by an Auditing Party in enforcing this provision.

**3.28 Drug-free Workplace to be Maintained by Contractor**

During the performance of this contract, the agrees to (i) provide a drug-free workplace for CONTRACTOR's employees; (ii) post in conspicuous places, available to employees and applicants for employment, a statement notifying employees that the unlawful manufacture, sale, distribution, dispensation, possession, or use of a controlled substance or marijuana is

**IFB 23-067**

**Commercial Diver Services to Clean Potomac River Offshore, and Onshore Intakes**

prohibited in CONTRACTOR's workplace and specifying the actions that will be taken against employees for violations of such prohibition; (iii) state in all solicitations or advertisements for employees placed by or on behalf of CONTRACTOR that CONTRACTOR maintains a drug-free workplace; and (iv) include the provisions of the foregoing clauses in every subcontract or purchase order of over \$10,000, so that the provisions will be binding upon each subcontractor, subconsultant, or vendor. For purposes hereof, a "drug-free workplace" shall mean the site for the performance of the Work contemplated hereby.

**3.29 Non-Discrimination by CONTRACTOR**

CONTRACTOR covenants and agrees as follows:

(a) During the Term, CONTRACTOR will not discriminate against any employee or applicant for employment because of race, religion, color, sex, or national origin, except where religion, sex or national origin is a bona fide occupational qualification reasonably necessary to the normal operation of CONTRACTOR. CONTRACTOR agrees to post in conspicuous places, available to employees and applicants for employment, notices setting forth the provisions of this nondiscrimination clause.

(b) CONTRACTOR, in all solicitations or advertisements for employees placed by or on behalf of CONTRACTOR, will state that CONTRACTOR is an equal opportunity employer.

(c) Notices, advertisements, and solicitations placed in accordance with federal laws, rules, or regulations shall be deemed sufficient for the purpose of meeting the requirements of this Section.

CONTRACTOR will include the provisions of the foregoing Sections (a), (b), and (c) in every subcontract, sub consulting agreement, and purchase order over \$10,000, in order that the provisions above will be binding upon each subcontractor, subconsultant, and vendor.

**Payment to Subcontractors and Subconsultants.** Within seven days after receipt of each payment for services provided hereunder, CONTRACTOR shall:

(a) pay each subcontractor and/or subconsultant an amount equal to the percentage of the Services attributable to such subcontractor or subconsultant; or

(b) notify FW and each such subcontractor and/or subconsultant in writing of the intention to withhold all or part of the amounts due such subcontractor or subconsultant and state the reason for such nonpayment.

CONTRACTOR shall pay interest on amounts owed to any subcontractor and/or subconsultant which remain unpaid seven days after CONTRACTOR's receipt of payment for services provided hereunder, provided, however, that amounts owed any subcontractor and/or subconsultant which have been withheld properly pursuant to this Section, shall not accrue interest. Interest on amounts due any subcontractor and/or subconsultant and unpaid

**IFB 23-067**

**Commercial Diver Services to Clean Potomac River Offshore, and Onshore Intakes**

shall accrue at the rate of one-half of one percent (1%) per month; provided, however that CONTRACTOR's obligation to pay interest hereunder shall in no event be construed to be an obligation of FW. No contract modification shall be made, and no cost reimbursement claim shall be submitted, for purposes of reimbursement for the interest charge. CONTRACTOR shall include in each of its subcontracts a provision requiring each of its subcontractors and/or subconsultants to include or otherwise be subject to the same payment and interest requirements with respect to each lower tier subcontractor and/or subconsultant.

**3.30 Counterparts**

This IFB and any amendments or renewals hereto may be executed in a number of counterparts, and each counterpart signature, when taken with the other counterpart signatures, is treated as if executed upon one original of this Contract or any amendment or renewal. A signature by any party to this Contract provided by facsimile or electronic mail is binding upon that party as if it were the original.

**3.31 Survival of Terms**

Any agreement resulting from this IFB shall upon discharge of the Agreement, Sections (Notice, Hold Harmless, Warranties, Governing Law/Forum, Contractual Disputes) of these Terms and Conditions continue and survive in full force and effect.

**3.32 Non-Waiver**

No waiver of any provision of this IFB shall constitute a waiver of any other provision nor shall any waiver of this Agreement constitute a continuing waiver unless otherwise expressly provided.

**3.33 Dispute Resolution Process**

Contractual claims, whether for money or for other relief, will be submitted in writing to FW not later than 60 days after final payment; provided however, that written notice of CONTRACTOR's intention to file such claim must:

- a. be delivered to the attention of FW's Procurement Manager, at the address shown in the notice provisions of the MSA, not later than five days after the occurrence or of the beginning of the Work upon which the claim is based; and
- b. contain a reasonably detailed description of the basis of the claim.

CONTRACTOR's failure to comply with the foregoing requirements will result in waiver of the claim. FW will make a written decision upon any such claim within 60 days after submittal of the claim. CONTRACTOR will not institute legal action prior to receipt of FW's decision on the claim unless FW fails to render such decision within 90 days after submittal of the claim. The decision of FW will be final, unless CONTRACTOR initiates legal action as provided in § 2.2-4364 of the Virginia Code. Failure of FW to render a decision within 90 days will not result in CONTRACTOR being awarded the relief

## **IFB 23-067**

### **Commercial Diver Services to Clean Potomac River Offshore, and Onshore Intakes**

claimed, nor will it result in any other relief or penalty. The sole result of FW's failure to render a decision within the time allotted will be CONTRACTOR's right to immediately institute legal action. No administrative appeals procedure pursuant to § 2.2-4365 of the Virginia Code has been established for contractual claims under this IFB.

#### **4. SPECIAL TERMS AND CONDITIONS**

##### **4.1 Contractor's Compliance and Safety Program**

- A. The Contractor shall comply with all applicable Federal, State, and local safety programs, regulations, standards, and codes, to include though not limited to:
  - 1. The Virginia Uniform Statewide Building Code,
  - 2. Building Officials & Code Administrators (BOCA) codes (together with adopted International Codes),
  - 3. Virginia Department of Health (VDH) regulations,
  - 4. Virginia Department of Environmental Quality (DEQ) regulations,
  - 5. Virginia-OSH (VOSH) regulations, and
  - 6. National Electric Code (NEC).
  
- B. The Contractor shall have a written safety program that complies with all applicable OSHA and VOSH standards for General Industry regulations and a written Permit Required Confined Space Entry Program that complies with the then current VOSH Standard Confined Space Entry Standard. A copy of these programs shall be provided to FW with the Contractor's general safety program not later than seven days after contract award and before beginning work.
  
- C. When working in a confined space, the Contractor shall utilize only personnel trained for confined space entry and shall provide all entry equipment including atmospheric test equipment.
  
- D. Hard Hat Area: Contractor's employees shall wear hard hats while working outdoors at the work site.

##### **4.2 Contractor's Responsibilities**

- A. The Contractor shall be responsible for all products and/or services as required by this solicitation. The use of subcontractors is prohibited unless:
  - 1. A request to include a subcontractor is included in the proposal and,
  - 2. The Bidder receives written approval to use a subcontractor prior to, or as part of the formal contract between the parties.
  
- B. Even when properly authorized by FW, the use of a subcontractor does not relieve the Contractor of liability under the contract.

## IFB 23-067

### Commercial Diver Services to Clean Potomac River Offshore, and Onshore Intakes

- C. The Contractor, at its sole expense, shall be responsible for damage to FW and non-FW property as a result of its failure to protect such facilities and utilities.
- D. Where the Contractor's Work may cause damage or disrupt existing FW property including but not limited to utilities, plant equipment, instrumentation and control systems, etc. the Contractor shall make all necessary arrangements for the protection of such property. The Contractor, at its sole expense, shall immediately replace FW property removed or damaged by, or at the direction of, the Contractor or any Subcontractor to the Contractor. Replacements will be new and current technology unless otherwise provided for in these specifications or authorized by the FW Project Manager.
- E. Contractor shall return all work areas to the same or better condition than prior to start of Work. Contractor must notify the FW Project Manager of any area, piece of equipment, etc., that is damaged or not in the same or better condition than prior to start of Work. The Contractor will be responsible for repair, replacement, etc., of any such property, which is within the Contractor's area of responsibility and is found to be in need of repair/service by the FW Project Manager. Acceptance shall not occur until all such damages are either repaired or replaced or for which FW is reimbursed a fair and reasonable sum as negotiated and agreed to in writing, by the FW Project Manager.

#### 4.3 Delays

- A. By the Contractor: After prior written warning to the Contractor, FW may declare the Contractor in default for unacceptable delays. If such a declaration is made, FW reserves the unilateral right to cure the default by any means available to FW, including (but not limited to) liquidated damages, redeeming the Contractor's Performance Bond (or other security as agreed to by FW prior to contract award); and to recover any additional costs, lost funds and/or related expenses. This is not a limitation of FW's legal rights to recover damages due to Contractor default in any other way.
- B. By FW: The Contractor shall not be responsible for delays caused by FW, its agents, or other Contractors. To the extent that the Contractor is unable to proceed due to the actions or inaction's of FW, its agents, employees or other Contractors, the Contractor shall be granted an extension to the installation schedule equal to the documented amount of time the Contractor was prevented from performing work. The Contractor shall not be eligible for damages as a result of FW delays.

#### 4.4 Force Majeure

If a delivery is delayed by Act of God, terrorism, war, embargo, fire, or explosion not caused by the negligence or intentional act of the Contractor or his subcontractors or supplier(s), a reasonable extension of time as FW or the Member deems appropriate may be granted. Upon receipt of a written request and justification for any extension from the Contractor, FW or the Member may in its sole discretion (i) extend the time for delivery of the Commodity; (ii) suspend the Contract in whole or in part and obtain one or more of the Commodities elsewhere for a time, or (iii) terminate the Contract; all without liability to Contractor on the

## **IFB 23-067**

### **Commercial Diver Services to Clean Potomac River Offshore, and Onshore Intakes**

part of FW or Member, as the case may be. Contractor's request and justification shall be subject to such substantiation and further inquiries as FW or Member may require.

#### **4.5 Inspection of Job Site**

- A. Pre-Existing Conditions: By submitting an offer in response to this solicitation, Bidder agrees that it will perform a diligent site tour. Bidders confirm that the price elements contained in its financial proposal reflect any and all conditions under which the work must be accomplished. After contract award, any claim based upon conditions that the Contractor should reasonably have discovered during the site survey will not be considered by FW.
- B. Changes to Existing Conditions: Contractor shall promptly notify the Project Manager or his designee of any site changes that may affect the Project as soon as such changes are discovered. Work in the affected area shall be halted until the Project Manager or his designee inspects the newly discovered condition. To the extent that such changes affect the scope of the contract, the Contractor shall submit a written proposal for any work necessary to complete the Project. Such proposals shall be submitted within ten days of discovery and shall include a detailed listing of all additional price changes to FW.

#### **4.6 Priority Customer**

By submitting a Bid in response to this solicitation, Bidder understands and acknowledges that FW provides services that are essential to the health and welfare of the public. To the extent that the Contractor must prioritize and/or allocate services among its customers, the requirements of FW will be honored before service is provided to a customer with no obligations with regard to the public health and welfare.

#### **4.7 Site Safety and Access**

- A. The Contractor shall schedule and coordinate the Work and install temporary facilities as required to maintain continuous operation and access to existing equipment in the area of Work. The Contractor shall not commence retrofit work until authorized by the FW Project Manager. The Contractor is advised that FW may, at its sole discretion, delay or stop work as required to ensure continuous and reliable operation of the facility, especially during peak flow events.
- B. The Contractor shall secure the Site and all areas of Work to prevent access and the potential for injury to its employees, FW employees, its agents, and others by construction and installation of temporary guard-rails, fencing, barricades, highway cones, warning signs/tape, etc., and/or other appropriate means, and as directed by the FW Project Manager. Such hazards include but are not limited to mechanical hazards, electrical hazards, surface irregularities or construction tools and equipment.

## IFB 23-067

### Commercial Diver Services to Clean Potomac River Offshore, and Onshore Intakes

- C. FW shall have the right to deny access to the Site, or require the Contractor to remove from the Site, any individual who has exhibited violent, abusive, or threatening behavior or conduct.
- D. FW may limit, restrict, or prohibit access to areas of the Site on a permanent or temporary basis. When access to such restricted areas is required by the Contractor to perform the Work, the Contractor shall obtain permission from the FW Project Manager and shall comply with such conditions or limitations to access as may be imposed by the FW Project Manager.
- E. FW may restrict parking or require parking permits for vehicles to be brought onto the plant. The Contractor shall be responsible for arranging transportation for its personnel to reach the job sites from whatever parking area is provided by FW.

#### 4.8 Superintendence by Contractor

- A. The Contractor shall have a competent Field Supervisor, satisfactory to FW, on the job site at all times during the progress of the Work. The Contractor shall be responsible for coordinating all portions of the Work under contract except where otherwise specified in the contract documents, and for all safety and worker health programs and practices. The Contractor shall notify the Project Manager, in writing, of any proposed change in superintendent including the reason therefore prior to making such change.
- B. The Contractor shall at all times enforce strict discipline and good order among the workers on the project. The Contractor shall not employ on the Project any unfit person, anyone not skilled in the work assigned to him, or anyone who will not work in harmony with those employed by the Contractor, subcontractors, FW or FW's separate Contractors and their subcontractors.
- C. FW may, in writing, require the Contractor to remove from FW property, any employee FW deems to be incompetent, careless, not working in harmony with others on the site, or otherwise objectionable.

#### 4.9 Time Is Of The Essence

**This is a time critical project!** Once started, this project must continue without delay or interruption, and unauthorized delays by the Contractor are prohibited. After prior written warning to the Contractor, FW may declare the Contractor in default for unacceptable delays. If such a declaration is made, FW reserves the unilateral right to cure the default by obtaining the services of a qualified Contractor to complete the project and charge any additional or increased costs to the Contractor.

**IFB 23-067**  
**Commercial Diver Services to Clean Potomac River Offshore, and Onshore Intakes**

**ATTACHMENT 1**  
**BID SUBMISSION FORM**

COMPANY NAME: \_\_\_\_\_

ADDRESS: \_\_\_\_\_

CONTACT PERSON: \_\_\_\_\_

TELEPHONE: \_\_\_\_\_ E-MAIL: \_\_\_\_\_

FAX: \_\_\_\_\_ FED ID #: \_\_\_\_\_

Pursuant to Title 13.1 or Title 50 of the Virginia Code provide the identification number issued to your firm by the Virginia State Corporation Commission (VSCC) in the space provided below, If your firm is not required to be authorized to transact business under Title 13.1 or Title 50, or any other law; provide a statement why your firm is not required to be so authorized.

_____	_____
Company Name	Identification Number

If you do not have a VSCC identification number, explain why it is not required in the space below:

\_\_\_\_\_

\_\_\_\_\_

\_\_\_\_\_

Item No.	Item Description	Quantity	Unit	Unit Price	Total Cost/ Item
1	Base Proposal (Mobilization & Setup)	1	Lump Sum	N/A	\$
2	Offshore Intake Work Tasks (See Section 2.2 A,) (Total Cost Per Foot Based on Average Depth per Quadrant)	4	Feet		\$
3	Onshore Intake-Work Tasks (See Section 2.2 B)	1	Lump Sum	N/A	\$
4	<b>TOTAL AMOUNT PROPOSED</b> (Items 1 through 3 inclusive)				\$

Estimated number of days to complete Item 2 \_\_\_\_\_. Item 3 \_\_\_\_\_.

**NOTE** – Item No. 2 shall be inclusive of all work described in Section 2.2 A. Per Section 2.2, Scope of Work, Paragraphs A.1. a, b, and c, any adjustments to the base bid price for Bid Item 2 shall be reflective of the percentage of re-cleaning that may become necessary.

**IFB 23-067**  
**Commercial Diver Services to Clean Potomac River Offshore, and Onshore Intakes**

**ATTACHMENT 1**  
**BID SUBMISSION FORM**

\*All bids are to be quoted as FOB Destination. Include all necessary costs in your quote submission (see above). Failure to include the cost of mobilization and contractor overhead will be interpreted as included in the unit price for each item. FW will not pay for any additional charges not included in your bid.

- **TERMS:** \_\_\_\_\_ All bids will be interpreted as Net 30 unless otherwise specified herein. FW's minimum payment term is Net 30 days. By submitting an offer to sell in response to this solicitation, all bidders acknowledge and agree to this requirement.

By my signature I certify that I am acting as an agent or in the case of an LLP, the Partner or Managing Partner for the firm identified below and I am fully authorized to bind the firm to the terms, conditions and specifications of this solicitation, as well as any addenda thereto.

Company Name: \_\_\_\_\_

Signature: \_\_\_\_\_

Printed Name: \_\_\_\_\_

Title: \_\_\_\_\_ Date: \_\_\_\_\_

**IFB 22-062**  
**Commercial Diver Services to Clean Potomac River Offshore, and Onshore Intakes**

**ATTACHMENT 2**  
**REFERENCES**

BIDDER'S NAME: \_\_\_\_\_

1. COMPANY NAME: \_\_\_\_\_

ADDRESS: \_\_\_\_\_

\_\_\_\_\_

\_\_\_\_\_

CONTACT PERSON: \_\_\_\_\_

TELEPHONE: (\_\_\_\_\_) - \_\_\_\_\_ - \_\_\_\_\_

FAX: (\_\_\_\_\_) - \_\_\_\_\_ - \_\_\_\_\_

E-MAIL: \_\_\_\_\_

2. COMPANY NAME: \_\_\_\_\_

ADDRESS: \_\_\_\_\_

\_\_\_\_\_

\_\_\_\_\_

CONTACT PERSON: \_\_\_\_\_

TELEPHONE: (\_\_\_\_\_) - \_\_\_\_\_ - \_\_\_\_\_

FAX: (\_\_\_\_\_) - \_\_\_\_\_ - \_\_\_\_\_

E-MAIL: \_\_\_\_\_

3. COMPANY NAME: \_\_\_\_\_

ADDRESS: \_\_\_\_\_

\_\_\_\_\_

\_\_\_\_\_

CONTACT PERSON: \_\_\_\_\_

TELEPHONE: (\_\_\_\_\_) - \_\_\_\_\_ - \_\_\_\_\_

FAX: (\_\_\_\_\_) - \_\_\_\_\_ - \_\_\_\_\_

E-MAIL: \_\_\_\_\_

## DAILY DIVER INSPECTION FORM

<b>DATE</b>	<b>INSPECTOR NAME:</b>	<b>FILL IN BOX</b>
	CONTRACTOR START TIME:	
	CONTRACTOR STOP TIME:	
	CONTRACTOR EQUIP. USED:	
	NUMBER OF CONTRACTORS ON SITE:	
	PUMP HOUR METER READING	
	ESTIMATED AMOUNT OF MATERIAL REMOVED CU.FT.	
	BRIEF DESCRIPTION OF WORK PERFORMED	
	(INCLUDING ANY EQUIPMENT DELAYS):	

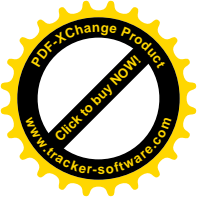

# 742 High Boom Load Zone Charts

### Standard Carriage-Decal 100169

### Rotate Carriage-Decal 100174

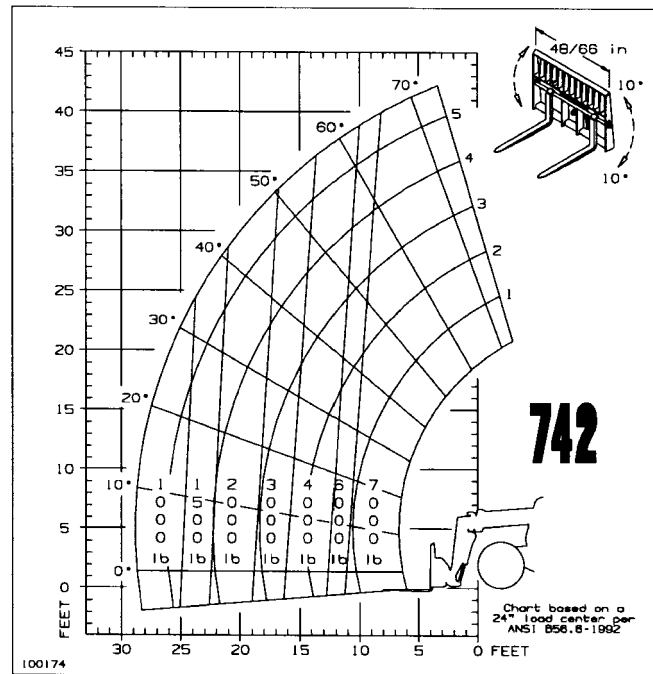
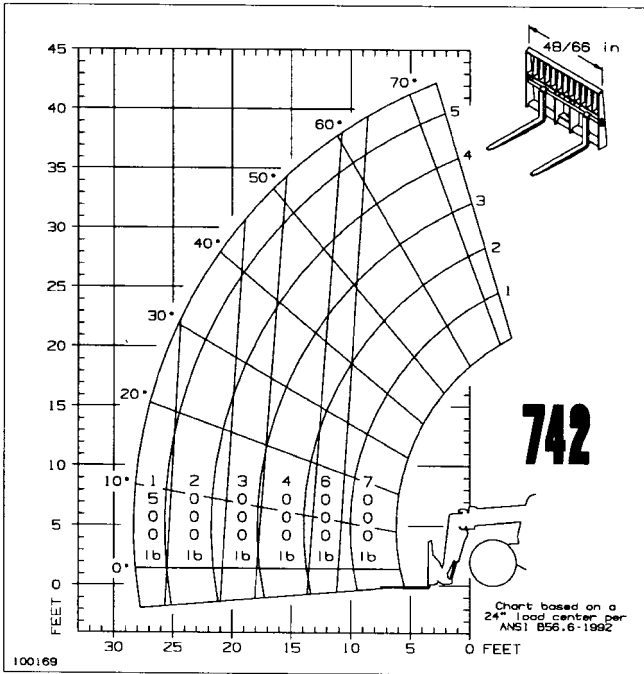

# 742 High Boom Load Zone Charts

### 12 Ft. Truss Boom-Decal 100170

### 15 Ft. Truss Boom-Decal 100171

